

**NOIP1SN025KA,  
NOIP1SN016KA,  
NOIP1SN012KA**



**ON Semiconductor®**

[www.onsemi.com](http://www.onsemi.com)

## **PYTHON 25K/16K/12K Global Shutter CMOS Image Sensors**

### **Features**

- A Pin-compatible Family with Multiple Resolutions:
  - ◆ 25K = 5120 x 5120 Active Pixels
  - ◆ 16K = 4096 x 4096 Active Pixels
  - ◆ 12K = 4096 x 3072 Active Pixels
- 4.5  $\mu\text{m}$  x 4.5  $\mu\text{m}$  Low Noise Global Shutter Pixels with In-pixel Correlated Double Sampling (CDS)
- APS-H Optical Format (32.6 mm Diagonal) for 25K
- Monochrome (SN), Color (SE) and NIR (FN)
- Random Programmable Region of Interest (ROI) Readout
- Pipelined and Triggered Global Shutter
- On-chip Fixed Pattern Noise (FPN) Correction
- 10-bit Analog-to-Digital Converter (ADC)
- 32 Low-voltage Differential Signaling (LVDS) High-speed Serial Outputs
- Serial Peripheral Interface (SPI)
- High-speed: 80 Frames per Second (fps) at 25 Mpix
- 4.6 W Power Dissipation at Full Resolution, x32 LVDS Mode
- Operational Range:  $-40^{\circ}\text{C}$  to  $+85^{\circ}\text{C}$
- 355-pin  $\mu\text{PGA}$  Package
- These Devices are Pb-Free and are RoHS Compliant

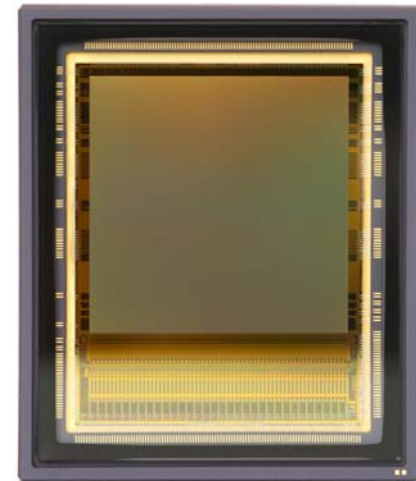

**Figure 1. PYTHON XK Photograph**

### **Applications**

- Machine Vision
- Motion Monitoring
- Intelligent Traffic Systems (ITS)
- Pick and Place Machines
- Inspection
- Metrology

### **Description**

The PYTHON xK family of CMOS image sensors provide high resolution with very high bandwidth (up to 80 frame per second readout for 25 megapixel readout) in a pin-compatible family of devices.

The high sensitivity 4.5  $\mu\text{m}$  pixels support both pipelined and triggered global shutter readout modes. The sensor also supports correlated double sampling (CDS) readout in global shutter mode, reducing noise and increasing dynamic range.

The sensor is programmed using a four-wire serial peripheral interface. Black level can be calibrated automatically, or adjusted using a user programmable offset. The sensor also supports readout of up to 32 separate regions of interest (ROI) to increase frame rate. Image data is accessed through 32, 16, 8, or 4 LVDS channels, each running at 720 Mbps, and a separate synchronization channel is provided to facilitate image reconstruction.

The PYTHON xK family is packaged in a 355-pin  $\mu\text{PGA}$  package and is available in a monochrome, Bayer color, and extended near-infrared (NIR) configurations.

# NOIP1SN025KA, NOIP1SN016KA, NOIP1SN012KA

## ORDERING INFORMATION

Part Number	Family	Description	Package	Product Status
NOIP1SN025KA-GDI	PYTHON 25K	25 MegaPixel, Monochrome, no Protective Tape	355-pin $\mu$ PGA	Production
NOIP1FN025KA-GDI		25 MegaPixel, NIR, no Protective Tape		
NOIP1SE025KA-GDI		25 MegaPixel, Color, no Protective Tape		
NOIP1SN025KA-GTI		25 MegaPixel, Monochrome, Protective Tape		
NOICP1SN025KA-GTI		25 MegaPixel, Monochrome, Protective Tape, Grade 2 (Note 1)		
NOIP1FN025KA-GTI		25 MegaPixel, NIR, Protective Tape		
NOIP1SE025KA-GTI		25 MegaPixel, Color, Protective Tape		
NOIP1SN016KA-GDI	PYTHON 16K	16 MegaPixel, Monochrome, no Protective Tape		
NOIP1FN016KA-GDI		16 MegaPixel, NIR, no Protective Tape		
NOIP1SE016KA-GDI		16 MegaPixel, Color, no Protective Tape		
NOIP1SN016KA-GTI		16 MegaPixel, Monochrome, Protective Tape		
NOIP1FN016KA-GTI		16 MegaPixel, NIR, Protective Tape		
NOIP1SE016KA-GTI		16 MegaPixel, Color, Protective Tape		
NOIP1SN012KA-GDI	PYTHON 12K	12 MegaPixel, Monochrome, no Protective Tape		
NOIP1FN012KA-GDI		12 MegaPixel, NIR, no Protective Tape		
NOIP1SE012KA-GDI		12 MegaPixel, Color, no Protective Tape		
NOIP1SN012KA-GTI		12 MegaPixel, Monochrome, Protective Tape		
NOIP1FN012KA-GTI		12 MegaPixel, NIR, Protective Tape		
NOIP1SE012KA-GTI		12 MegaPixel, Color, Protective Tape		

1. For Grade 2 definition, please refer to the Acceptance Criteria (available upon request).

The P1-SN/SE/FN base part is used to reference the mono, color and NIR enhanced versions of the LVDS interface. More details on the part number coding can be found at [http://www.onsemi.com/pub\\_link/Collateral/TND310-D.PDF](http://www.onsemi.com/pub_link/Collateral/TND310-D.PDF)

### Package Mark

Side 1 near Pin 1: **NOIP1xx0RRKA-GTI** where xx denotes mono micro lens (SN) or color micro lens (SE) or NIR mono micro lens (FN), RR is the resolution of the sensor in MP (25, 16 or 12)

Side 2: **AWLYYWW**, where AWL is Production lot traceability, and YYWW is the 4-digit date code

# NOIP1SN025KA, NOIP1SN016KA, NOIP1SN012KA

## SPECIFICATIONS

### Key Specifications

**Table 1. GENERAL SPECIFICATIONS**

Parameter	Specification
Pixel Type	Global shutter pixel architecture
Shutter Type	Pipelined and triggered global shutter
Optical Format	25K: APS-H 16K: APS-H 12K: 4/3"
Frame Rate at Full Resolution	80 frames per second @ 25K 120 frames per second @ 16K 160 frames per second @ 12K
Master Clock	360 MHz
Windowing	32 Randomly programmable windows. Normal and sub-sampled readout modes
ADC Resolution (Note 2)	10-bit
LVDS Outputs	32 data + 1 sync + 1 clock
Data Rate	32 x 720 Mbps
Power Consumption	4.6 W
Package Type	355 $\mu$ PGA
Color	RGB color, mono

2. The ADC is 11-bit, down-scaled to 10-bit. The PYTHON XK uses a larger word-length internally to provide 10-bit on the output.

**Table 2. ELECTRO-OPTICAL SPECIFICATIONS**

Parameter	Specification
Active Pixels	25K: 5120 (H) x 5120 (V) 16K: 4096 (H) x 4096 (V) 12K: 4096 (H) x 3072 (V)
Pixel Size	4.5 $\mu$ m x 4.5 $\mu$ m
Conversion Gain	0.085 LSB $_{10}$ /e $^{-}$ , 130 $\mu$ V/e $^{-}$
Temporal Noise	< 14 e $^{-}$ (Non-Zero ROT, 1x gain)
Responsivity at 550 nm	5.8 V/lux.s
Parasitic Light Sensitivity (PLS)	< 1/5000
Full Well Charge	> 12000 e $^{-}$
Quantum Efficiency (QE) x FF	50% at 550 nm
Pixel FPN (Note 3)	< 0.9 LSB $_{10}$
PRNU (Note 3)	< 1%
MTF	68% @ 535 nm – X-dir & Y-dir 68% @ 535 nm – X-dir & Y-dir (NIR)
PSNL @ 20°C (t $_{int}$ = 30 ms)	91 LSB $_{10}$ /s, 1100 e $^{-}$ /s
Dark signal @ 20°C	3.9 e $^{-}$ /s, 0.33 LSB $_{10}$ /s
Dynamic range	59 dB
Signal-to-Noise Ratio (SNR max)	41 dB

3. Only includes high-frequency component

# NOIP1SN025KA, NOIP1SN016KA, NOIP1SN012KA

**Table 3. RECOMMENDED OPERATING RATINGS** (Note 4)

Symbol	Description	Min	Max	Units
T <sub>J</sub>	Operating temperature range	-40	+85	°C

Functional operation above the stresses listed in the Recommended Operating Ranges is not implied. Extended exposure to stresses beyond the Recommended Operating Ranges limits may affect device reliability.

**Table 4. ABSOLUTE MAXIMUM RATINGS** (Note 5)

Symbol	Parameter	Min	Max	Units
ABS (1.0 V supply)	ABS rating for 1.0 V supply	-0.5	1.2	V
ABS (1.8 V supply group)	ABS rating for 1.8 V supply group	-0.5	2.2	V
ABS (3.3 V supply group)	ABS rating for 3.3 V supply group	-0.5	4.3	V
ABS (4.2 V supply)	ABS rating for 4.2 V supply	-0.5	4.6	V
T <sub>S</sub> (Notes 5 and 6)	ABS storage temperature range	0	150	°C
	ABS storage humidity range at 85°C		85	%RH
Electrostatic discharge (ESD) (Notes 4 and 5)	Human Body Model (HBM): JS-001-2010	2000		V
	Charged Device Model (CDM): JESD22-C101	500		
LU	Latch-up: JESD-78	140		mA

Stresses exceeding those listed in the Maximum Ratings table may damage the device. If any of these limits are exceeded, device functionality should not be assumed, damage may occur and reliability may be affected.

4. Operating ratings are conditions in which operation of the device is intended to be functional.
5. ON Semiconductor recommends that customers become familiar with, and follow the procedures in JEDEC Standard JESD625-A. Refer to Application Note AN52561. Long term exposure toward the maximum storage temperature will accelerate color filter degradation.
6. Caution needs to be taken to avoid dried stains on the underside of the glass due to condensation. The glass lid glue is permeable and can absorb moisture if the sensor is placed in a high % RH environment.

**Table 5. ELECTRICAL SPECIFICATIONS**

**Boldface Limits apply for T<sub>J</sub> = T<sub>MIN</sub> to T<sub>MAX</sub>.** all other limits T<sub>J</sub> = +30°C (Notes 7, 8, 9 and 10)

Parameter	Description	Min	Typ	Max	Units
<b>Power Supply Parameters</b>					
vdda_33	Analog supply - 3.3 V domain. gnda_33 is connected to substrate	<b>3.2</b>	3.3	<b>3.4</b>	V
idda_33	Current consumption from analog supply		910		mA
vddd_33	Digital supply - 3.3 V domain. gndd_33 is connected to substrate	<b>3.2</b>	3.3	<b>3.4</b>	V
idd_33	Current consumption from 3.3 V digital supply		90		mA
vdd_18	Digital supply - 1.8 V domain. gndd_18 is connected to substrate	<b>1.7</b>	1.8	<b>1.9</b>	V
idd_18	Current consumption 1.8 V digital supply		540		mA
vdd_pix	Pixel array supply	<b>3.25</b>	3.3	<b>3.35</b>	V
idd_pix	Current consumption from pixel supply		115		mA
vdd_resfd	Floating diffusion reset supply		4.2		V
gnd_resfd	Floating diffusion reset ground. Not connected to substrate <b>Note</b> This is a sinking power supply with 200 mA range.		0		V
vdd_trans	Pixel transfer supply		3.3		V
gnd_trans	Pixel transfer ground. Not connected to substrate. <b>Note</b> This is a sinking power supply with 200 mA range.		0		V
vdd_calib	Pixel calibration supply		4.2		V

7. All parameters are characterized for DC conditions after thermal equilibrium is established.
8. This device contains circuitry to protect the inputs against damage due to high static voltages or electric fields. However, it is recommended that normal precautions be taken to avoid application of any voltages higher than the maximum rated voltages to this high-impedance circuit.
9. Minimum and maximum limits are guaranteed through test and design.
10. Vref\_colmux supply should be able to source and sink current

# NOIP1SN025KA, NOIP1SN016KA, NOIP1SN012KA

**Table 5. ELECTRICAL SPECIFICATIONS**

**Boldface Limits apply for  $T_J = T_{MIN}$  to  $T_{MAX}$ ; all other limits  $T_J = +30^\circ\text{C}$  (Notes 7, 8, 9 and 10)**

Parameter	Description	Min	Typ	Max	Units
gnd_calib	Pixel calibration ground. Not connected to substrate		0		V
vdd_sel	Pixel select supply		4.2		V
gnd_sel	Pixel select ground. Not connected to substrate.	0	0	0	V
vdd_casc	Cascode supply		1.0		V
vref_colmux [10]	Column multiplexer reference supply		1.0		V
gnd_colbias	Column biasing ground. Dedicated ground signal for pixel biasing. Connected to substrate		0		V
gnd_colpc	Column precharge ground. Dedicated ground signal for pixel biasing. Not connected to substrate		0		V
Ptot	Total power consumption		4600		mW
Popt	Power consumption at lower pixel rates	Configurable			

**I/O - LVDS (EIA/TIA-644): Conforming to standard/additional specifications and deviations listed**

fserdata	Data rate on data channels DDR signaling - 32 data channels, 1 synchronization channel			720	Mbps
fserclock	Clock rate of output clock Clock output for mesochronous signaling			360	MHz
Vicm	LVDS input common mode level	0.3	1.25	2.2	V
Tccsk	Channel to channel skew (training pattern allows per-channel skew correction)			50	ps

**LVDS Electrical/Interface**

fin	Input clock rate			360	MHz
tfdc	Input clock duty cycle	45	50	55	%
tj	Input clock jitter		20		ps
fspi	SPI clock rate			10	MHz
ratspi	10-bit (32 LVDS channels): ratio: fin/fspi	30			
	10-bit (16 LVDS channels): ratio: fin/fspi	60			
	10-bit (8 LVDS channels): ratio: fin/fspi	120			
	10-bit (4 LVDS channels): ratio: fin/fspi	240			

7. All parameters are characterized for DC conditions after thermal equilibrium is established.
8. This device contains circuitry to protect the inputs against damage due to high static voltages or electric fields. However, it is recommended that normal precautions be taken to avoid application of any voltages higher than the maximum rated voltages to this high-impedance circuit.
9. Minimum and maximum limits are guaranteed through test and design.
10. Vref\_colmux supply should be able to source and sink current

# NOIP1SN025KA, NOIP1SN016KA, NOIP1SN012KA

**Table 5. ELECTRICAL SPECIFICATIONS**

**Boldface Limits apply for  $T_J = T_{MIN}$  to  $T_{MAX}$ ; all other limits  $T_J = +30^\circ C$  (Notes 7, 8, 9 and 10)**

Parameter	Description	Min	Typ	Max	Units
-----------	-------------	-----	-----	-----	-------

**Sensor Requirements**

FOT	Frame overhead time		50		$\mu s$
ROT	Row overhead time		2		$\mu s$
fpix	Pixel rate (32 channels at 72 Mpix/s)			2304	Mpix/s

**Frame Specifications**

		Typical		Max	Units
		Non-Zero ROT	Zero ROT		
fps_roi1	Xres x Yres = 5120 x 5120	47	80		fps
fps_roi2	Xres x Yres = 4096 x 4096	65	120		fps
fps_roi3	Xres x Yres = 4096 x 3072	85	160		fps
fps_roi4	Xres x Yres = 3840 x 2896	95	175		fps
fps_roi5	Xres x Yres = 3840 x 2160	125	235		fps
fps_roi6	Xres x Yres = 2880 x 2896	105	175		fps
fps_roi7	Xres x Yres = 2048 x 2048	170	250		fps
fpix	Pixel rate (32 channels at 72 Mpix/s)			2304	Mpix/s

7. All parameters are characterized for DC conditions after thermal equilibrium is established.
8. This device contains circuitry to protect the inputs against damage due to high static voltages or electric fields. However, it is recommended that normal precautions be taken to avoid application of any voltages higher than the maximum rated voltages to this high-impedance circuit.
9. Minimum and maximum limits are guaranteed through test and design.
10. Vref\_colmux supply should be able to source and sink current

**Disclaimer:** Image sensor products and specifications are subject to change without notice. Products are warranted to meet the production data sheet and acceptance criteria specifications only.

**Color Filter Array**

The PYTHON XK color sensor is processed with a Bayer RGB color pattern as shown in Figure 2. Pixel (0,0) has a red filter situated to the bottom left. Green1 and green2 have a slightly different spectral response due to (optical) cross talk from neighboring pixels. Green1 pixels are located on a green-red row, green2 pixels are located on a blue-green row.



**Figure 2. Color Filter Array for the Pixel Array**

# NOIP1SN025KA, NOIP1SN016KA, NOIP1SN012KA

## Quantum Efficiency

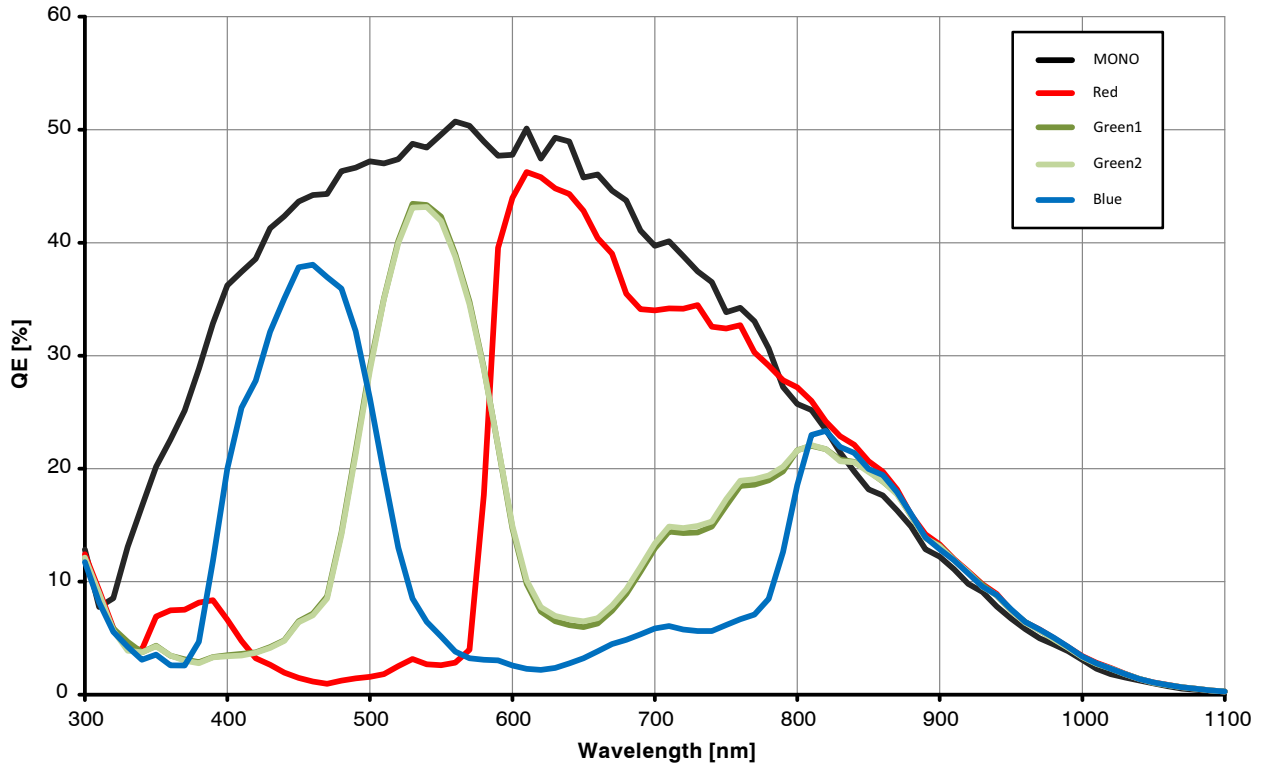

Figure 3. Quantum Efficiency Curve for Mono and Color

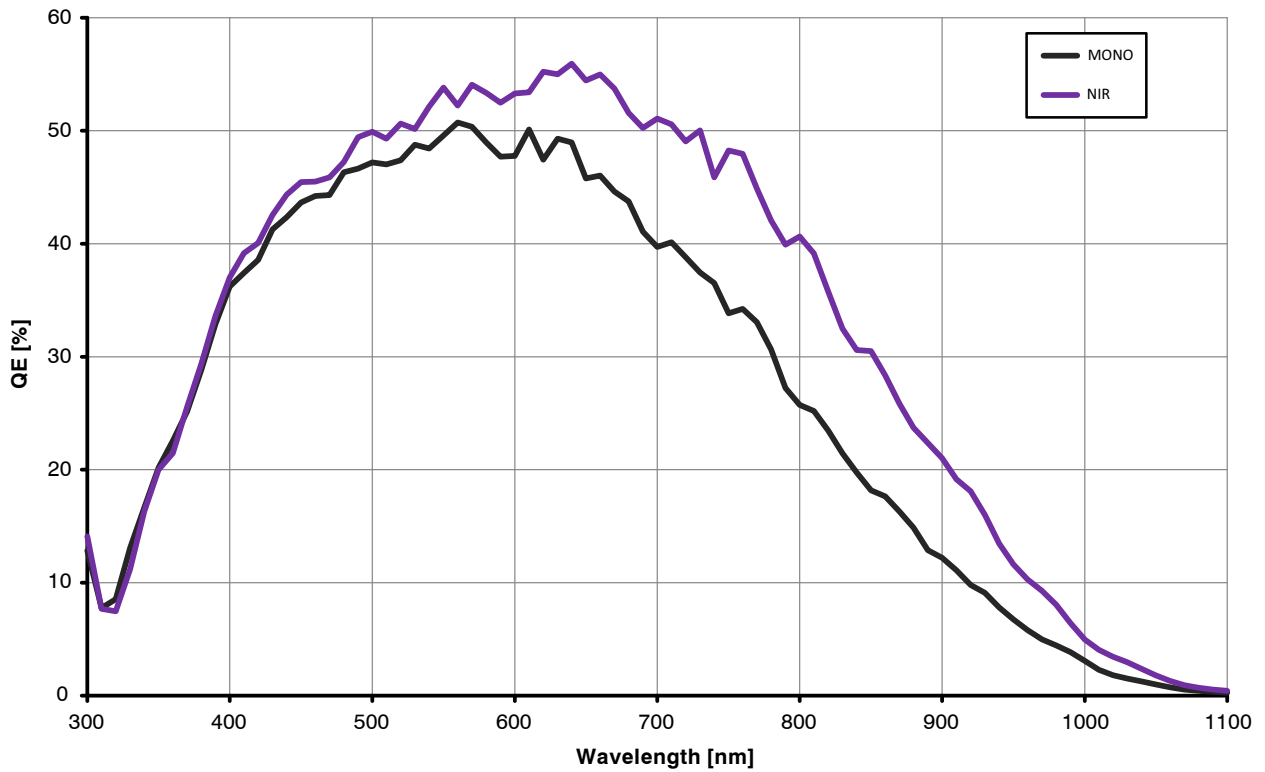

Figure 4. Quantum Efficiency Curve for Standard and NIR Mono

**Ray Angle and Microlens Array Information**

An array of microlenses is placed over the CMOS pixel array in order to improve the absolute responsivity of the photodiodes. The combined microlens array and pixel array has two important properties:

1. Angular dependency of photoresponse of a pixel  
The photoresponse of a pixel with microlens in the center of the array to a fixed optical power with varied incidence angle is as plotted in Figure 5, where definitions of angles  $\phi_x$  and  $\phi_y$  are as described by Figure 6.
2. Microlens shift across array and CRA  
The microlens array is fabricated with a slightly

smaller pitch than the array of photodiodes. This difference in pitch creates a varying degree of shift of a pixel's microlens with regards to its photodiode. A shift in microlens position versus photodiode position will cause a tilted angle of peak photoresponse, here denoted Chief Ray Angle (CRA). Microlenses and photodiodes are aligned with 0 shift and CRA in the center of the array, while the shift and CRA increases radially towards its edges, as illustrated by Figure 7.



## NOIP1SN025KA, NOIP1SN016KA, NOIP1SN012KA

The purpose of the shifted microlenses is to improve the uniformity of photoresponse when camera lenses with a finite exit pupil distance are used. In the standard version of PYTHONxK, the CRA varies nearly linearly with distance

from the center as illustrated in Figure 8, with a corner CRA of approximately 10.6 degrees (for 5120 x 5120 resolution). This edge CRA is matching a lens with exit pupil distance of ~85 mm.



Note that the photoresponse peaks near normal incidence for center pixels.

Figure 5. Center Pixel Photoresponse to a Fixed Optical Power with Incidence Angle Varied Along  $\phi_X$  and  $\phi_Y$

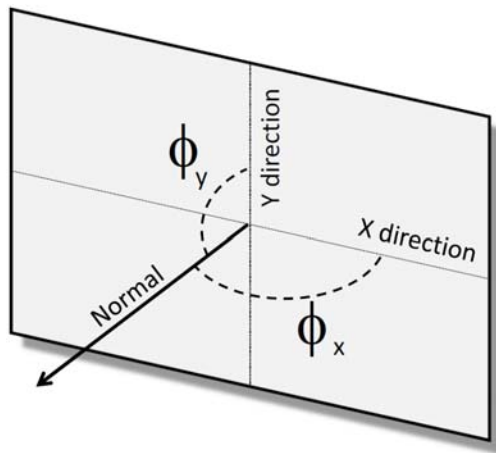

Figure 6. Definition of Angles used in Figure 5.

# NOIP1SN025KA, NOIP1SN016KA, NOIP1SN012KA



The center axes of the microlens and the photodiode coincide for the center pixels. For the edge pixels, there is a shift between the axis of the microlens and the photodiode causing a peak response incidence angle (CRA) that deviates from the normal of the pixel array.

**Figure 7. Principle of Microlens Shift**

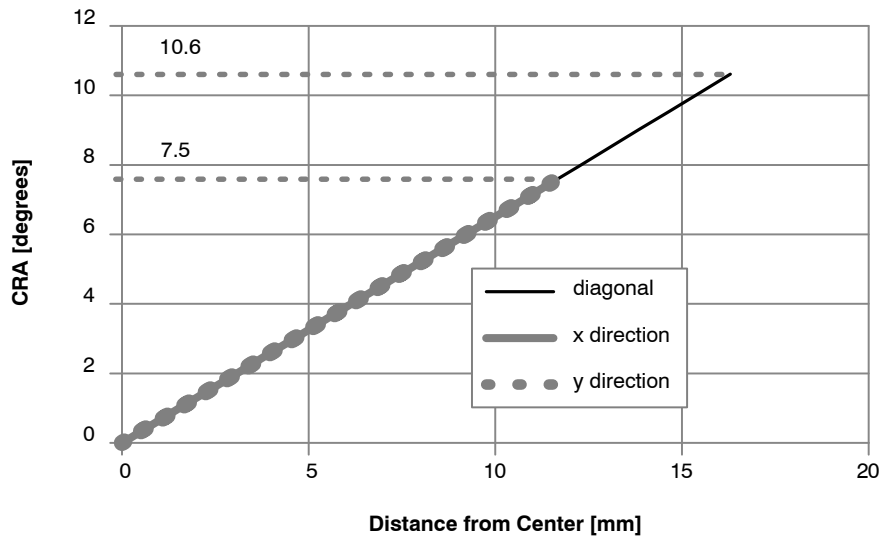

**Figure 8. Variation of Peak Responsivity Angle (CRA) as a Function of Distance from the Center of the Array**

OVERVIEW

Figure 9 gives an overview of the major functional blocks of the PYTHON sensor.



Figure 9. Block Diagram

**Image Core**

The image core consists of:

- Pixel array
- Address decoders and row drivers
- Pixel biasing

The PYTHON 25MP pixel array contains 5120 (H) x 5120 (V) readable pixels with a pixel pitch of 4.5  $\mu\text{m}$ .

The PYTHON 16MP/12MP/10MP image arrays contain 4224 (H) x 4112 (V) / 4224 (H) x 3088 (V) / 3968 (H) x 2912 (V) readable pixels, inclusive of 8 pixel rows and 64 pixel columns at every side to allow for reprocessing or color reconstruction. The sensor uses in-pixel CDS architecture, which makes it possible to achieve a low noise read out of the pixel array in both global shutter shutter mode with CDS.

The function of the row drivers is to access the image array to reset or read the pixel data. The row drivers are controlled by the on-chip sequencer and can access the pixel array.

The pixel biasing block guarantees that the data on a pixel is transferred properly to the column multiplexer when the row drivers select a pixel line for readout.

**LVDS Clock Receiver**

The LVDS clock receiver receives an LVDS clock signal and distributes the required clocks to the sensor.

Typical input clock frequency is 360 MHz. The clock input needs to be terminated with a 100  $\Omega$  resistor.

**Column Multiplexer**

The 5120 pixels of one image row are stored in 5120 column sample-and-hold (S/H) stages. These stages store both the reset and integrated signal levels.

The data stored in the column S/H stages is read out through 64 parallel differential outputs operating at a frequency of 36 MHz.

At this stage, the reset signal and integrated signal values are transferred into an FPN-corrected differential signal. A programmable gain of 1x, 2x, or 4x can be applied to the signal at this stage. The column multiplexer also supports a subsampled readout mode (read-1-skip-1 for mono and read-2-skip-2 for color version). Enabling this mode can speed up the frame rate, with a decrease in resolution.

### Bias Generator

The bias generator generates all required reference voltages and bias currents that the on-chip blocks use. An external resistor of 47 k $\Omega$ , connected between the pins *ibias\_master* and *ibias\_out* is required for the bias generator to operate properly.

### Analog Front End

The AFE contains 64 channels, each containing a PGA and a 10-bit ADC.

For each of the 64 channels, a pipelined 10-bit ADC is used to convert the analog image data into a digital signal, which is delivered to the data formatting block. A black calibration loop is implemented to ensure that the black level is mapped to match the correct ADC input level.

### Data Formatting

The data block receives data from two ADCs and multiplexes this data to one LVDS block. A cyclic redundancy check (CRC) code is calculated on the passing data. For each LVDS output channel, one data block is instantiated. An extra data block is foreseen to transmit synchronization codes such as frame start, line start, frame end, and line end indications.

The data block calculates a CRC once per line for every channel. This CRC code can be used for error detection at the receiving end.

### Serializer and LVDS Interface

The serializer and LVDS interface block receives the formatted (10-bit) data from the data formatting block. This data is serialized and transmitted by the LVDS output driver.

The maximum output data bit rate is 720 Mbps per channel.

In addition to the 32 LVDS data outputs, two extra LVDS outputs are available. One of these outputs carries the output clock, which is skew aligned to the output data channels. The second LVDS output contains frame format synchronization codes to serve system-level image reconstruction.

### Sequencer

The sequencer:

- Controls the image core. Starts and stops integration and controls pixel readout.
- Operates the sensor in master or slave mode.
- Applies the window settings. Organizes readouts so that only the configured windows are read.
- Controls the column multiplexer and analog core. Applies gain settings and subsampling modes at the correct time, without corrupting image data.
- Starts up the sensor correctly when leaving standby mode.

OPERATING MODES

**Global Shutter Mode**

The PYTHON operates in pipelined or triggered global shutter modes. In this mode, light integration takes place on all pixels in parallel, although subsequent readout is sequential. Figure 10 shows the integration and readout sequence for the global shutter mode. All pixels are light sensitive at the same period of time. The whole pixel core is reset simultaneously and after the integration time all pixel values are sampled together on the storage node inside each pixel. The pixel core is read out line by line after integration. Note that the integration and readout can occur in parallel or sequentially. The integration starts at a certain period, relative to the frame start.



Figure 10. Global Shutter Operation

**Pipelined Global Shutter Mode**

In pipelined global shutter mode, the integration and readout are done in parallel. Images are continuously read and integration of frame N is ongoing during readout of the previous frame N-1. The readout of every frame starts with a frame overhead time (FOT), during which the analog value on the pixel diode is transferred to the pixel memory element. After the FOT, the sensor is read out line by line and the readout of each line is preceded by the row overhead time (ROT). Figure 11 shows the exposure and readout time line in pipelined global shutter mode.

*Master Mode*

In this operation mode, the integration time is set through the register interface and the sensor integrates and reads out the images autonomously. The sensor acquires images without any user interaction.

*Slave Mode*

The slave mode adds more manual control to the sensor. The integration time registers are ignored in this mode and the integration time is instead controlled by an external pin. As soon as the control pin is asserted, the pixel array goes out of reset and integration starts. The integration continues until the user or system deasserts the external pin. Upon a falling edge of the trigger input, the image is sampled and the readout begins.



Figure 11. Pipelined Shutter Operation in Master Mode



Figure 12. Pipelined Shutter Operation in Slave Mode

**Triggered Global Shutter**

In this mode, manual intervention is required to control both the integration time and the start of readout. After the integration time, indicated by a user controlled pin, the image core is read out. After this sequence, the sensor goes to an idle mode until a new user action is detected.

The three main differences from the pipelined shutter master mode are:

- Upon user action, a single image is read.
- Normally, integration and readout are done sequentially. However, the user can control the sensor in such a way that two consecutive batches are overlapping, that is, having concurrent integration and readout.
- Integration and readout is user-controlled through an external pin. This mode requires manual intervention for every frame. The pixel array is kept in reset state until requested.

The triggered global mode can also be controlled in a master or in a slave mode.

*Master Mode*

In this mode, a rising edge on the synchronization pin is used to trigger the start of integration and readout. The integration time is defined by a register setting. The sensor autonomously integrates during this predefined time, after which the FOT starts and the image array is readout sequentially. A falling edge on the synchronization pin does not have any impact on the readout or integration and subsequent frames are started again for each rising edge. Figure 13 shows the relation between the external trigger signal and the exposure/readout timing. If a rising edge is applied on the external trigger before the exposure time and FOT of the previous frame is complete, it is ignored by the sensor.

*Slave Mode*

Integration time control is identical to the pipelined shutter slave mode. An external synchronization pin controls the start of integration. When it is de-asserted, the FOT starts. The analog value on the pixel diode is transferred to the pixel memory element and the image readout can start. A request for a new frame is started when the synchronization pin is asserted again.



**Figure 13. Triggered Shutter Operation in Master Mode**

**Non-Zero and Zero Row Overhead Time (ROT) Modes**

In pipelined global shutter mode, the integration and readout are done in parallel. Images are continuously read out and integration of frame N is ongoing during readout of the previous frame N-1. The readout of every frame starts with a Frame Overhead Time (FOT), during which the analog value of the pixel diode is transferred to the pixel memory element. After the FOT, the sensor is read out line by line and the readout of each line is preceded by a Row Overhead Time (ROT) as shown in Figure 14.

In Reduced/Zero ROT operation mode (refer to Figure 15), the row blanking and kernel readout occur in parallel. This mode is called reduced ROT as a part of the ROT is done while the image row is readout. The actual ROT is done while the image row is readout. The actual ROT can thus be longer, however the perceived ROT will be shorter ('overhead' spent per line is reduced).

This operation mode can be used for two reasons:

- Reduced total line time.
- Lower power due to reduced clock rate.



**Figure 14. Integration and Readout Sequence of the Sensor Operating in Pipelined Global Shutter Mode with Non-Zero ROT Readout.**



**Figure 15. Integration and Readout Sequence of the Sensor operating in Pipelined Global Shutter Mode with Zero ROT Readout.**

**SENSOR OPERATION**

**Flowchart**

Figure 16 shows the flow chart diagram of the sensor operation. The sensor can be in five different ‘states’. Every state is indicated with an oval circle. These states are:

- Power-Off
- Standby (1)
- Standby (2)
- Idle
- Running

The states above are ordered by power dissipation. Clearly, in ‘power-off’ state the power dissipation will be minimal; in ‘running’ state the power dissipation will be maximal.

On the other hand, the lower the power consumption, the more actions (and time) are required to put the sensor in ‘running’ state and grab images.

This flowchart provides the trade-offs between power saving and enabling time of the sensor.

Next to the ‘states’ a set of ‘user actions’, indicated by arrows, are included in the flow chart diagram. These user actions make it possible to move from one state to another.

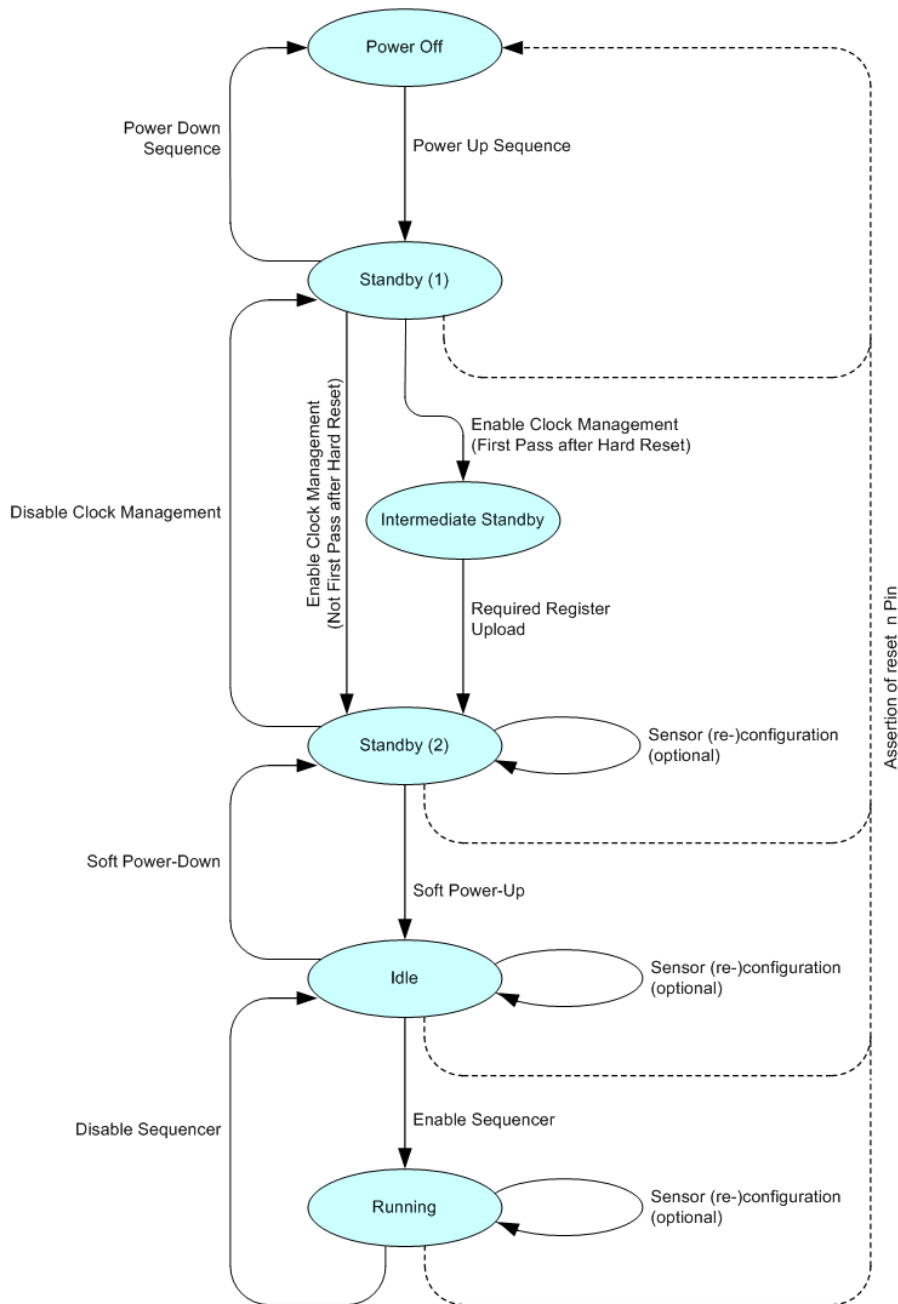

**Figure 16. Sensor Operation Flowchart**



# NOIP1SN025KA, NOIP1SN016KA, NOIP1SN012KA

## Sensor States

The sensor can be in five different states:

### Power-off

In this state, the sensor is inactive. All power supplies are down and the power dissipation is zero.

### Standby (1)

The registers below address 40 can be configured.

### Standby (2)

In this standby state all SPI registers are active, meaning that all SPI registers can be accessed for read and write operations. All other blocks are disabled.

Note: An Intermediate Standby state is traversed after a hard reset. In this state the sensor contains the default configurations. Uploads of reserved registers are required to traverse to the Standby (2) state

### Idle

In the idle state, all sensor clocks are running and all blocks are enabled, except the sequencer block. The sensor is ready to start grabbing images as soon as the sequencer block is enabled.

### Running

In running state, the sensor is enabled and grabbing images. The sensor can be operated in different global master/slave modes.

## User Actions: Power Up Functional Mode Sequences

### Power-up Sequence

Figure 17 shows the power-up timing of the sensor. Apply all power supplies in the order shown in the figure. It is important to comply with the described sequence. Any other supply ramping sequence may lead to high current peaks and, as a consequence, a failure of the sensor power up.

The clock input should start running when all supplies are stabilized. Note that before starting the clock, the LVDS output channel multiplexing (32, 16, 8 or 4), by connecting pins F24/F25 (muxmode0/1), should be set to the correct supply as described in Table 24 and Table 21.

When the clock frequency is stable, the reset\_n signal can be de-asserted. After a wait period of 10  $\mu$ s, the power up sequence is finished and the first SPI upload can be initiated.

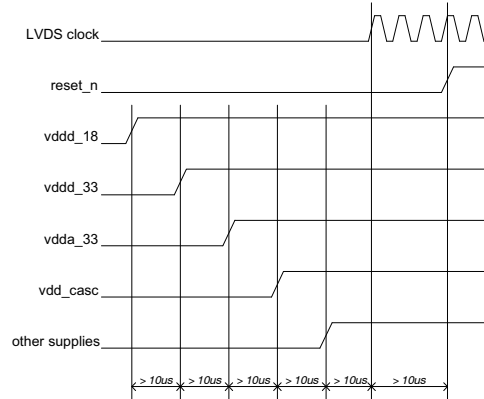

Figure 17. Power-up Procedure

NOTE: vdd\_casc should come up prior to vdd\_resfd, vdd\_trans, vdd\_calib and vdd\_sel.

### Enable Clock Management

The 'Enable Clock Management' action configures the clock management blocks in a pre-defined way. The required uploads are available to customers under NDA at the ON Semiconductor Image Sensor Portal: <https://www.onsemi.com/PowerSolutions/myon/erCispFol der.do>

## NOIP1SN025KA, NOIP1SN016KA, NOIP1SN012KA

### Required Register Uploads

In this phase the 'reserved' register settings are uploaded through the SPI register. Different settings are not allowed and may cause the sensor to malfunction.

### Soft Power Up

During the soft power-up action, the internal blocks are enabled and prepared to start processing the image data stream. This action exists of a set of SPI uploads.

### Enable Sequencer

During the 'Enable Sequencer'-action, the frame grabbing sequencer is enabled. The sensor will start grabbing images in the configured operation mode. Refer to Operating Modes on page 13 for an overview of the possible operation modes.

The 'Enable Sequencer' action consists of enabling bit 192[0].

### Disable Sequencer

During the 'Disable Sequencer'-action, the frame grabbing sequencer is stopped. The sensor will stop grabbing images and returns to the idle mode.

The 'Disable Sequencer' action consists of disabling bit 192[0].

### Soft Power Down

During the soft power-down action, the internal blocks are disabled and the sensor is put in standby state in order to reduce the current dissipation. This action exists of a set of register uploads.

### Disable Clock Management

The 'Disable Clock Management'-action stops the internal clocking in order to further decrease the power dissipation.

### Power-down Sequence

The timing diagram of the advised power-down sequence is given in Figure 18. Any other sequence might cause high peak currents.

NOTE: vdd\_casc should be powered down after vdd\_resfd, vdd\_trans, vdd\_calib and vdd\_sel.

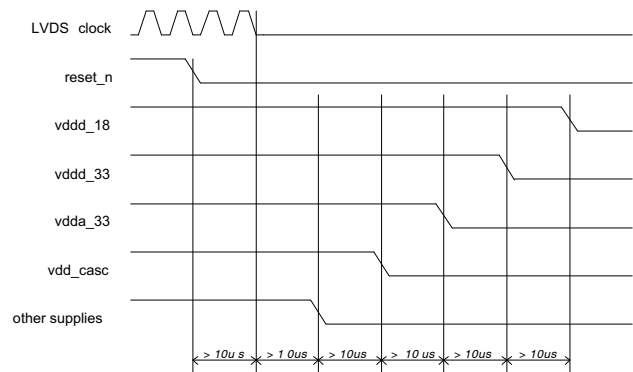

Figure 18. Power-down Sequence

Table 6. SHUTTER/OPERATION MODE CONFIGURATION REGISTERS

Address	Default Value	Description
192 [4]	0x0	Triggered mode selection 0: Normal mode 1: Triggered mode
192 [5]	0x0	Master/Slave selection 0: Master mode 1: Slave mode
192 [7]	0x0	Subsampling mode selection 0: Subsampling disabled 1: Subsampling enabled

### Windowing Reconfiguration

The windowing settings can be configured during standby, idle, and running mode.

The required regions of interest (ROI) can be programmed in the roi\_configuration registers (addresses 256 up to 351). Registers roi\_active0 and roi\_active1 are used to activate the desired ROIs.

Default window configuration (after sensor reset) is one window, full frame (window #0).

### Exposure/Gain Reconfiguration

The exposure time and gain settings can be configured during standby, idle, and running mode. Refer to Signal Gain Path on page 30 for more information.

# NOIP1SN025KA, NOIP1SN016KA, NOIP1SN012KA

## Sensor Configuration

This device contains multiple configuration registers. Some of these registers can only be configured while the sensor is not acquiring images (while register 192[0] = 0), while others can be configured while the sensor is acquiring images. For the latter category of registers, it is possible to distinguish the register set that can cause corrupted images (limited number of images containing visible artifacts) from the set of registers that are not causing corrupted images.

These three categories are described here.

## Static Readout Parameters

Some registers are only modified when the sensor is not acquiring images. Reconfiguration of these registers while images are acquired can cause corrupted frames or even interrupt the image acquisition. Therefore, it is recommended to modify these static configurations while the sequencer is disabled (register 192[0] = 0). The registers are shown in Table 7. Table 7 should not be reconfigured during image acquisition. A specific configuration sequence applies for these registers. Refer to the operation flow and startup description.

**Table 7. STATIC READOUT PARAMETERS**

Group	Addresses	Description
Clock generator	32	Configure according to recommendation
Image core	40	Configure according to recommendation
AFE	48	Configure according to recommendation
Bias	64–71	Configure according to recommendation
LVDS	112	Configure according to recommendation
Sequencer mode selection	192	<ul style="list-style-type: none"> <li>triggered_mode</li> <li>slave_mode</li> </ul>
All reserved registers		Keep reserved registers to their default state, unless otherwise described in the recommendation

## Dynamic Configuration Potentially Causing Image Artifacts

The category of registers as shown in Table 8 consists of configurations that do not interrupt the image acquisition process, but may lead to one or more corrupted images

during and after the reconfiguration. A corrupted image is an image containing visible artifacts. A typical example of a corrupted image is an image which is not uniformly exposed

The effect is transient in nature and the new configuration is applied after the transient effect.

**Table 8. DYNAMIC CONFIGURATION POTENTIALLY CAUSING IMAGE ARTIFACTS**

Group	Addresses	Description
Black level configuration	128–129 197[12:8]	Reconfiguration of these registers may have an impact on the black-level calibration algorithm. The effect is a transient number of images with incorrect black level compensation.
Sync codes	129[13] 116–126	Incorrect sync codes may be generated during the frame in which these registers are modified.
Datablock test configurations	144–150	Modification of these registers may generate incorrect test patterns during a transient frame.

## Dynamic Readout Parameters

It is possible to reconfigure the sensor while it is acquiring images. Frame-related parameters are internally resynchronized to frame boundaries, such that the modified parameter does not affect a frame that has already started. However, there can be restrictions to some registers as shown in Table 9.

Some reconfiguration may lead to one frame being blanked. This happens when the modification requires more than one frame to settle. The image is blanked out and training patterns are transmitted on the data and sync channels.

**Table 9. DYNAMIC READOUT PARAMETERS**

Group	Addresses	Description
Subsampling	192[7]	Subsampling is synchronized to a new frame start.
ROI configuration	195-196 256-351	An ROI switch is only detected when a new window is selected as the active window (reconfiguration of registers 195, 196, or both). Reconfiguration of the ROI dimension of the active window does not lead to a frame blank and can cause a corrupted image.
Exposure reconfiguration	199-201	Exposure reconfiguration does not cause artifact. However, a latency of one frame is observed unless reg_seq_exposure_sync_mode is set to '1' in triggered global mode (master).
Gain reconfiguration	204	Gains are synchronized at the start of a new frame. Optionally, one frame latency can be incorporated to align the gain updates to the exposure updates (refer to register 204[13] gain_lat_comp).

*Freezing Active Configurations*

Though the readout parameters are synchronized to frame boundaries, an update of multiple registers can still lead to a transient effect in the subsequent images, as some configurations require multiple register uploads. For example, to reconfigure the exposure time in master global mode, both the fr\_length and exposure registers need to be updated. Internally, the sensor synchronizes these configurations to frame boundaries, but it is still possible that the reconfiguration of multiple registers spans over two or even more frames. To avoid inconsistent combinations, freeze the active settings while altering the SPI registers by disabling synchronization for the corresponding functionality before reconfiguration. When all registers are uploaded, re-enable the synchronization. The sensor’s sequencer then updates its active set of registers and uses them for the coming frames. The freezing of the active set of registers can be programmed in the sync\_configuration registers, which can be found at the SPI address 206.

Figure 19 shows a reconfiguration that does not use the sync\_configuration option. As depicted, new SPI configurations are synchronized to frame boundaries.

When sync\_configuration = ‘1’, configurations are synchronized to the frame boundaries (The registers exposure, fr\_length, and mult\_timer are not used in this mode)

Figure 20 shows the usage of the sync\_configuration settings. Before uploading a set of registers, the corresponding sync\_configuration is deasserted. After the upload is completed, the sync\_configuration is asserted again and the sensor resynchronizes its set of registers to the coming frame boundaries. As seen in the figure, this ensures that the uploads performed at the end of frame N+2 and the start of frame N+3 become active in the same frame (frame N+4).



**Figure 19. Frame Synchronization of Configurations (no freezing)**



**Figure 20. Reconfiguration Using Sync\_configuration**

**NOTE:** SPI updates are not taken into account while sync\_configuration is inactive. The active configuration is frozen for the sensor. Table 10 lists the several sync\_configuration possibilities along with the respective registers being frozen.

**Table 10. ALTERNATE SYNC CONFIGURATIONS**

Group	Affected Registers	Description
sync_black_lines	black_lines	Update of black line configuration is not synchronized at start of frame when '0'. The sensor continues with its previous configurations.
sync_exposure	mult_timer fr_length exposure	Update of exposure configurations is not synchronized at start of frame when '0'. The sensor continues with its previous configurations.
sync_gain	mux_gainsw afe_gain	Update of gain configurations is not synchronized at start of frame when '0'. The sensor continues with its previous configurations.
sync_roi	roi_active0[15:0] roi_active1[15:0] subsampling	Update of active ROI configurations is not synchronized at start of frame when '0'. The sensor continues with its previous configurations. <b>Note:</b> The window configurations themselves are not frozen. Re-configuration of active windows is not gated by this setting.

**Window Configuration**

*Global Shutter Mode*

Up to 32 windows can be defined in global shutter mode (pipelined or triggered). The windows are defined by registers 256 to 351. Each window can be activated or deactivated separately using registers 195 and 196. It is possible to reconfigure the inactive windows while acquiring images. Switching between predefined windows is achieved by activation of the respective windows. This way a minimum number of registers need to be uploaded when it is necessary to switch between two or more sets of windows. As an example of this, scanning the scene at higher frame rates using multiple windows and switching to full frame capture when the object is tracked. Switching between the two modes only requires an upload of one (if the total number of windows is smaller than 17) or two (if more than 16 windows are defined) registers.

**Black Calibration**

The sensor automatically calibrates the black level for each frame. Therefore, the device generates a configurable number of electrical black lines at the start of each frame. The desired black level in the resulting output interface can be configured and is not necessarily targeted to '0'. Configuring the target to a higher level yields some information on the left side of the black level distribution, while the other end of the distribution tail is clipped to '0' when setting the black level target to '0'.

The black level is calibrated for the 64 columns contained in one kernel. This implies 64 black level offsets are generated and applied to the corresponding columns. Configurable parameters for the black-level algorithm are listed in Table 11.

# NOIP1SN025KA, NOIP1SN016KA, NOIP1SN012KA

**Table 11. CONFIGURABLE PARAMETERS FOR BLACK LEVEL ALGORITHM**

Group	Addresses	Description
<b>Black Line Generation</b>		
197[7:0]	black_lines	This register configures the number of black lines that are generated at the start of a frame. At least one black line must be generated. The maximum number is 255. <b>Note:</b> When the automatic black-level calibration algorithm is enabled, make sure that this register is configured properly to produce sufficient black pixels for the black-level filtering. The number of black pixels generated per line is dependent on the operation mode and window configurations: Each black line contains 80 kernels.
197[12:8]	gate_first_line	A number of black lines are blanked out when a value different from 0 is configured. These blanked out lines are not used for black calibration. It is recommended to enable this functionality, because the first line can have a different behavior caused by boundary effects. When enabling, the number of black lines must be set to at least two in order to have valid black samples for the calibration algorithm.
<b>Black Value Filtering</b>		
129[0]	auto_blackcal_enable	Internal black-level calibration functionality is enabled when set to '1'. Required black level offset compensation is calculated on the black samples and applied to all image pixels. When set to '0', the automatic black-level calibration functionality is disabled. It is possible to apply an offset compensation to the image pixels, which is defined by the registers 129[10:1]. <b>Note:</b> Black sample pixels are not compensated; the raw data is sent out to provide external statistics and, optionally, calibrations.
129[9:1]	blackcal_offset	Black calibration offset that is added or subtracted to each regular pixel value when auto_blackcal_enable is set to '0'. The sign of the offset is determined by register 129[10] (blackcal_offset_dec). <b>Note:</b> All channels use the same offset compensation when automatic black calibration is disabled. The calculated black calibration factors are frozen when this register is set to 0x1FF (all-'1') in auto calibration mode. Any value different from 0x1FF re-enables the black calibration algorithm. This freezing option can be used to prevent eventual frame to frame jitter on the black level as the correction factors are recalculated every frame. It is recommended to enable the black calibration regularly to compensate for temperature changes.
129[10]	blackcal_offset_dec	Sign of blackcal_offset. If set to '0', the black calibration offset is added to each pixel. If set to '1', the black calibration offset is subtracted from each pixel. This register is not used when auto_blackcal_enable is set to '1'.
128[10:8]	black_samples	The black samples are low-pass filtered before being used for black level calculation. The more samples are taken into account, the more accurate the calibration, but more samples require more black lines, which in turn affects the frame rate. The effective number of samples taken into account for filtering is $2^{\text{black\_samples}}$ . <b>Note:</b> An error is reported by the device if more samples than available are requested (refer to registers 136 to 139).
<b>Black Level Filtering Monitoring</b>		
136 137 138 139	blackcal_error0 blackcal_error1 blackcal_error2 blackcal_error3	An error is reported by the device if there are requests for more samples than are available (each bit corresponding to one data path). The black level is not compensated correctly if one of the channels indicates an error. There are three possible methods to overcome this situation and to perform a correct offset compensation: <ul style="list-style-type: none"> <li>• Increase the number of black lines such that enough samples are generated at the cost of increasing frame time (refer to register 197).</li> <li>• Relax the black calibration filtering at the cost of less accurate black level determination (refer to register 128).</li> <li>• Disable automatic black level calibration and provide the offset via SPI register upload. Note that the black level can drift in function of the temperature. It is thus recommended to perform the offset calibration periodically to avoid this drift.</li> </ul>

NOTE: The maximum number of samples taken into account for black level statistics is half the number of kernels.

**Serial Peripheral Interface**

The sensor configuration registers are accessed through an SPI. The SPI consists of four wires:

- sck: Serial Clock
- ss\_n: Active Low Slave Select
- mosi: Master Out, Slave In, or Serial Data In
- miso: Master In, Slave Out, or Serial Data Out

The SPI is synchronous to the clock provided by the master (sck) and asynchronous to the sensor’s system clock. When the master wants to write or read a sensor’s register, it selects the chip by pulling down the Slave Select line (ss\_n). When selected, data is sent serially and synchronous to the SPI clock (sck).

Figure 21 shows the communication protocol for read and write accesses of the SPI registers. The PYTHON XK sensor uses 9-bit addresses and 16-bit data words

Data driven by the system is colored blue in Figure 21, while data driven by the sensor is colored yellow. The data in grey indicates high-Z periods on the miso interface. Red markers indicate sampling points for the sensor (mosi sampling); green markers indicate sampling points for the system (miso sampling during read operations).

The access sequence is:

3. Select the sensor for read or write by pulling down the ss\_n line.
4. One SPI clock cycle (100 ns) after selecting the sensor, the 9-bit address is transferred, most

significant bit first. The sck clock is passed through to the sensor as indicated in Figure 21.

The sensor samples this data on a rising edge of the sck clock (mosi needs to be driven by the system on the falling edge of the sck clock)

5. The tenth bit sent by the master indicates the type of transfer: high for a write command, low for a read command.
6. Data transmission:
  - For write commands, the master continues sending the 16-bit data, most significant bit first.
  - For read commands, the sensor returns the requested address on the miso pin, most significant bit first. The miso pin must be sampled by the system on the falling edge of sck (assuming nominal system clock frequency and maximum 10 MHz SPI frequency).
7. When data transmission is complete, the system deselects the sensor one clock period after the last bit transmission by pulling ss\_n high.

Note the maximum frequency for the SPI interface needs to scale with the LVDS input clock frequency as described in Table 5.

Consecutive SPI commands can be issued by leaving at least two SPI clock periods between two register uploads. Deselect the chip between the SPI uploads by pulling the ss\_n pin high.

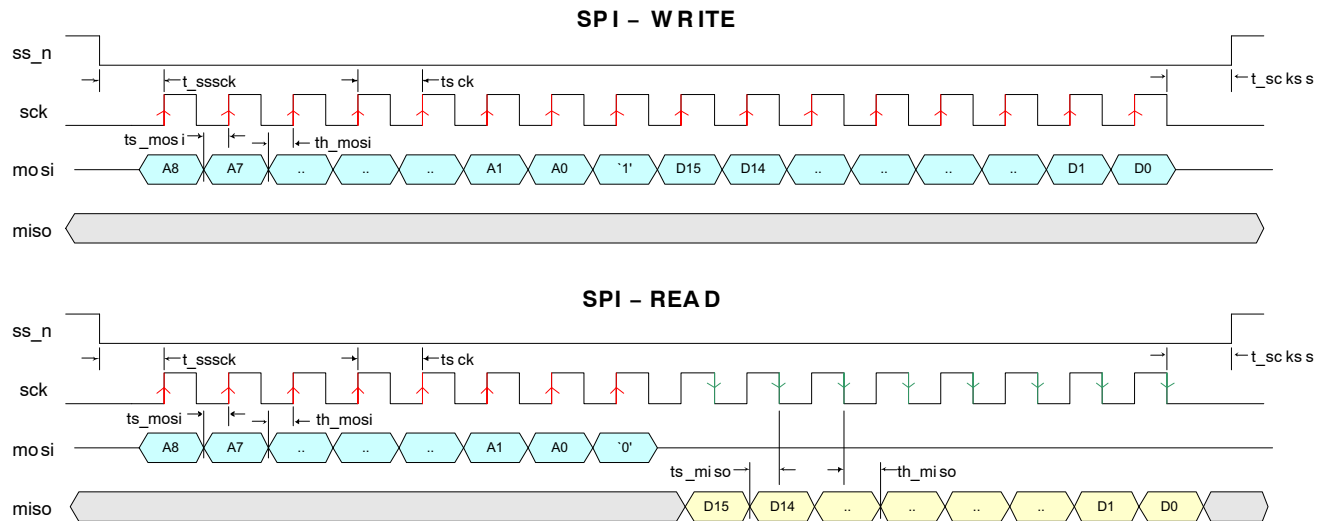

**Figure 21. SPI Read and Write Timing Diagram**

## NOIP1SN025KA, NOIP1SN016KA, NOIP1SN012KA

**Table 12. SPI TIMING REQUIREMENTS**

Group	Addresses	Description	Units
tsck	sck clock period	100 (*)	ns
tsssck	ss_n low to sck rising edge	tsck	ns
tsckss	sck falling edge to ss_n high	tsck	ns
ts_mosi	Required setup time for mosi	20	ns
th_mosi	Required hold time for mosi	20	ns
ts_miso	Setup time for miso	tsck/2-10	ns
th_miso	Hold time for miso	tsck/2-20	ns
tspi	Minimal time between two consecutive SPI accesses (not shown in figure)	2 x tsck	ns

\*Value indicated is for nominal operation. The maximum SPI clock frequency depends on the sensor configuration (operation mode, input clock). tsck is defined as  $1/f_{SPI}$ . See text for more information on SPI clock frequency restrictions.



## IMAGE SENSOR TIMING AND READOUT

**Global Shutter Mode***Pipelined Global Mode (Master)*

The sensor timing in master global shutter mode is controlled by the user by means of configuration registers. One can distinguish three parameters for the frame timing in global shutter mode:

- Image Array Reset Length
- Integration Time
- Frame Length

The relation between these parameters is:

$$\text{Frame Length} = \text{Reset Length} + \text{Integration Time}$$

The FOT time needs to be added to the frame length parameter to determine the total frame Time

$$\text{Total Frame Time} = \text{FOT Time} + \text{Frame Length}$$

Frame and integration time configuration can be controlled in two ways:

1.  $\text{fr\_mode} = 0x0$   
The reset length and integration time is configured by the user. The sensor shall calculate the frame length as the sum of both parameters.
2.  $\text{fr\_mode} = 0x1$   
The frame length and integration time is configured by the user. The reset time during which the pixels are reset, is calculated by the sensor as being the difference between the frame length and the desired integration time.

The configuration registers are  $\text{exposure}[15:0]$  and  $\text{fr\_length}[15:0]$ . The latter configuration register is either used as Reset Length configuration ( $\text{fr\_mode} = 0x0$ ) or as Frame Length ( $\text{fr\_mode} = 0x1$ ). The granularity of both registers is defined by the  $\text{mult\_timer}[15:0]$  register and is expressed in number of 72 MHz cycles (13.889 ns nominal).

**Reset Length and Integration Time as Parameters**

The reset time for the pixel array is controlled by the registers  $\text{fr\_length}[15:0]$  and  $\text{exposure}[15:0]$ . The  $\text{mult\_timer}$  configuration defines the granularity of the registers  $\text{fr\_length}$  and  $\text{exposure}$  and is to be read as the number of 72 MHz cycles (13.889 ns nominal).

The exposure control for pipelined global master mode is depicted in Figure 22.

The pixel values are transferred to the storage node during the FOT, after which all photo diodes are reset. The reset state remains active for a certain time, defined by the  $\text{fr\_length}$  and  $\text{mult\_timer}$  registers, as shown in the figure. Meanwhile, the image array is read out line by line. After this reset period, the global photodiode reset condition is abandoned. This indicates the start of the integration or

exposure time. The length of the exposure time is defined by the registers  $\text{exposure}$  and  $\text{mult\_timer}$ .

**NOTES:**

- The start of the exposure time is synchronized to the start of a new line (during ROT) if the exposure period starts during a frame readout. Therefore, the effective time during which the image core is in a reset state is extended to the start of a new line.
- Make sure that the sum of the reset time and exposure time exceeds the time required to read out all lines. If this is not the case, the exposure time is extended until all (active) lines are read out.

**Frame Length and Integration Time as Parameters**

When  $\text{fr\_mode}$  is configured to  $0x1$ , one configures the frame time and exposure. The  $\text{reset\_length}$  is determined by the sequencer. This configuration mode is depicted in Figure 2.

The frame length is configured in register  $\text{fr\_length}$ , while the integration time is configured in register  $\text{exposure}$ . The  $\text{mult\_timer}$  register defines granularity of both settings. Note that the FOT needs to be added to the configured  $\text{fr\_length}$  to calculate the total frame time.

*Triggered Global Shutter (Master)*

In master triggered global mode, the start of integration time is controlled by a rising edge on the trigger pin. The exposure or integration time is defined by the registers  $\text{exposure}$  and  $\text{mult\_timer}$ , similar to the master pipelined global mode. The  $\text{fr\_length}$  configuration is not used. This operation is graphically shown in Figure 24.

**NOTES:**

- The falling edge on the trigger pin does not have any impact. However, the trigger must be asserted for at least 100 ns.
- The start of the exposure time is synchronized to the start of a new line (during ROT) if the exposure period starts during a frame readout. Therefore, the effective time during which the image core is in reset state is extended to the start of a new line.
- The trigger pin needs to be kept low during the FOT. The monitor pins can be used as a feedback to the FPGA/controller (eg. use  $\text{monitor0}$ , indicating the very first line when  $\text{monitor\_select} = 0x5$  – a new trigger can be initiated after a rising edge on  $\text{monitor0}$ ).

If the exposure timer expires before the end of readout, the exposure time is extended until the end of the last active line.

## NOIP1SN025KA, NOIP1SN016KA, NOIP1SN012KA



**Figure 22. Integration Control for Pipelined Global Shutter Mode (Master, fr\_mode = 0x0)**



**Figure 23. Integration Control for Pipelined Global Shutter Mode (Master, fr\_mode = 0x1)**



**Figure 24. Exposure Time Control in Triggered Global Mode (Master)**

### Triggered Global Shutter (Slave)

Exposure or integration time is fully controlled by means of the trigger pin in slave mode. The registers fr\_length, exposure, and mult\_timer are ignored by the sensor.

A rising edge on the trigger pin indicates the start of the exposure time, while a falling edge initiates the transfer and readout of the image array. In other words, the high time of the trigger pin indicates the integration time, the period of the trigger pin indicates the frame time.

The use of the trigger during slave mode is shown in Figure 25.

#### NOTES:

- The start of the exposure time is synchronized to the start of a new line (during ROT) if the exposure period

starts during a frame readout. Therefore, the effective time during which the image core is in a reset state is extended to the start of a new line.

- If the trigger is deasserted before the end of readout, the exposure time is extended until the end of the last active line. Consequently the FOT and start of frame readout is postponed accordingly.
- The trigger pin needs to be kept low during the FOT. The monitor pins can be used as a feedback to the FPGA/controller (eg. use monitor0, indicating the very first line when monitor\_select = 0x5 – a new trigger can be initiated after a rising edge on monitor0).

# NOIP1SN025KA, NOIP1SN016KA, NOIP1SN012KA



**Figure 25. Exposure Time Control in Global-Slave Mode**

ADDITIONAL FEATURES

**Multiple Window Readout**

The PYTHON sensor supports multiple window readout, which means that only the user-selected Regions Of Interest (ROI) are read out. This allows limiting data output for every frame, which in turn allows increasing the frame rate. In global shutter mode, up to 32 ROIs can be configured.

**Window Configuration**

Figure 26 shows the four parameters defining a region of interest (ROI).



Figure 26. Region of Interest Configuration

- **x-start[6:0]**  
x-start defines the x-starting point of the desired window. The sensor reads out 64 pixels in one single clock cycle. As a consequence, the granularity for configuring the x-start position is also 64 pixels. The value configured in the x-start register is multiplied by 64 to find the corresponding column in the pixel array.
  - **x-end[6:0]**  
This register defines the window end point on the x-axis. Similar to x-start, the granularity for this configuration is one kernel. x-end needs to be larger than x-start.
  - **y-start[9:0]**  
The starting line of the readout window. The granularity of this setting is one line, except with color sensors where it needs to be an even number.
  - **y-end[9:0]**  
The end line of the readout window. y-end must be configured larger than y-start. This setting has the same granularity as the y-start configuration.
- Up to thirty-two windows can be defined, possibly (partially) overlapping, as illustrated in Figure 27.

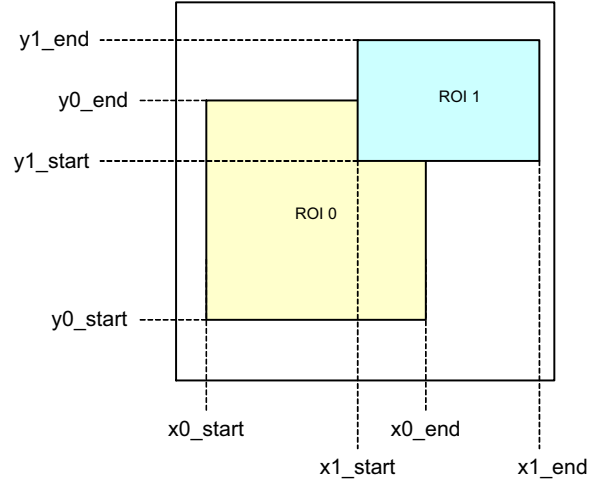

Figure 27. Overlapping Multiple Window Configuration

The sequencer analyses each line that need to be read out for multiple windows.

**Restrictions**

The following restrictions for each line are assumed for the user configuration:

- Windows are ordered from left to right, based on their x-start address:

$$x\_start\_roi(i) \leq x\_start\_roi(j) \text{ AND}$$

$$x\_end\_roi(i) \leq x\_end\_roi(j)$$

Where  $j > i$

**Processing Multiple Windows**

The sequencer control block houses two sets of counters to construct the image frame. As previously described, the y-counter indicates the line that needs to be read out and is incremented at the end of each line. For the start of the frame, it is initialized to the y-start address of the first window and it runs until the y-end address of the last window to be read out. The last window is configured by the configuration registers and it is not necessarily window #31.

The x-counter starts counting from the x-start address of the window with the lowest ID which is active on the addressed line. Only windows for which the current y-address is enclosed are taken into account for scanning. Other windows are skipped.

Figure 28 illustrates a practical example of a configuration with five windows. The current position of the

read pointer ( $ys$ ) is indicated by a red line crossing the image array. For this position of the read pointer, three windows need to be read out. The initial start position for the  $x$ -kernel pointer is the  $x$ -start configuration of ROI1. Kernels are scanned up to the ROI3  $x$ -end position. From there, the  $x$ -pointer jumps to the next window, which is ROI4 in this illustration. When reaching ROI4's  $x$ -end position, the read pointer is incremented to the next line and  $xs$  is reinitialized to the starting position of ROI1.

Notes:

- The starting point for the readout pointer at the start of a frame is the  $y$ -start position of the first active window.
- The read pointer is not necessarily incremented by one, but depending on the configuration, it can jump in  $y$ -direction. In Figure 28, this is the case when reaching the end of ROI0 where the read pointer jumps to the  $y$ -start position of ROI1
- The  $x$ -pointer starting position is equal to the  $x$ -start configuration of the first active window on the current line addressed. This window is not necessarily window #0.
- The  $x$ -pointer is not necessarily incremented by one each cycle. At the end of a window it can jump to the start of the next window.
- Each window can be activated separately. There is no restriction on which window and how many of the 8 windows are active.

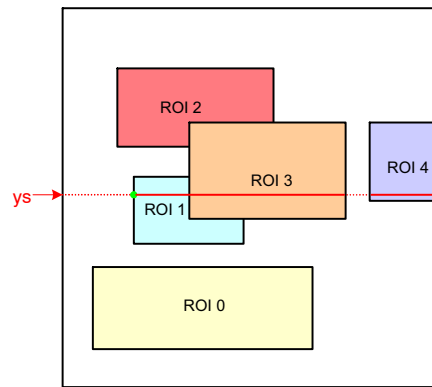

Figure 28. Scanning the Image Array with Five Windows

### Subsampling

Pixel subsampling methods are used as a way of decimating the image. The number of pixel samples is reduced by a factor of four, while the optical area is maintained.

Subsampling is obtained by adapting the readout sequence. In subsampling mode, both lines and pixels are read in a read- $N$ -skip- $N$  mode. This reduces the number of lines in a frame and the number of pixels in a line. Overall frame time is reduced by a factor 4.

Subsampling can be configured for the  $x$  and  $y$  direction independently by means of the `subsampling_mode` register.

The monochrome sensor is read out in a read-one-skip-one pattern for both the rows and the columns, while the color version supports a read-two-skip-two subsampling scheme. This mode is selectable through register configuration. Figure 29 shows which pixels are read and which ones are skipped for monochrome and color sensors respectively. Readout direction is indicated as an  $x$  and  $y$  arrow.



Figure 29. Subsampling Scheme for PYTHON XK

## NOIP1SN025KA, NOIP1SN016KA, NOIP1SN012KA

### Signal Gain Path

Table 13 and Table 14 show the available registers (fields) to program the desired exposure time and gain settings.

**Table 13. EXPOSURE TIME CONFIGURATION REGISTERS**

Address	Default Value	Description
201	0x0000	Exposure time: granularity defined by 'Mult Timer' (register 199).
199	0x0001	Mult Timer Defines granularity of exposure and reset length. unit = 1/72 MHz for normal ROT mode
200	0x0000	Reset length or Frame Length Granularity defined by 'Mult Timer' (register 199)

**Table 14. GAIN CONFIGURATION REGISTERS**

Address	Unity Gain Configuration	Description
204 [4:0]	0x04	0x04: 1x 0x18: 1.26x 0x08: 1.87x 0x10: 3.17x
204 [13]		Postpone gain update by one frame when '1' to compensate for exposure time updates latency.
205[11:0]	0x080	Digital Gain, 5.7 unsigned representation (5 bits before decimal point, 7 bits after fractional part). Maximum gain is 31.992

## NOIP1SN025KA, NOIP1SN016KA, NOIP1SN012KA

### Mode Changes and Frame Blanking

Dynamically reconfiguring the sensor may lead to corrupted or non-uniformly exposed frames. For some reconfigurations, the sensor automatically blanks out the image data during one frame. Frame blanking is

summarized in the following table for the sensor's image related modes.

NOTE: Major mode switching (i.e. switching between master, triggered or slave mode) must be performed while the sequencer is disabled (reg\_seq\_enable = 0x0).

**Table 15. DYNAMIC SENSOR RECONFIGURATION AND FRAME BLANKING**

Configuration	Corrupted Frame	Blanked Out Frame	Notes
<b>Shutter Mode and Operation</b>			
triggered_mode	Do not reconfigure while the sensor is acquiring images. Disable image acquisition by setting reg_seq_enable = 0x0.		
slave_mode	Do not reconfigure while the sensor is acquiring images. Disable image acquisition by setting reg_seq_enable = 0x0.		
subsampling	Enabling: No Disabling: Yes	Configurable	Configurable with blank_subsampling_ss register.
<b>Frame Timing</b>			
black_lines	No	No	
<b>Exposure Control</b>			
mult_timer	No	No	Latency is 1 frame
fr_length	No	No	Latency is 1 frame
exposure	No	No	Latency is 1 frame
<b>Gain</b>			
mux_gainsw	No	No	Latency configurable by means of gain_lat_comp register
afe_gain	No	No	Latency configurable by means of gain_lat_comp register.
db_gain	No	No	Latency configurable by means of gain_lat_comp register.
<b>Window/ROI</b>			
roi_active	See Note	No	Windows containing lines previously not read out may lead to corrupted frames.
roi*_configuration*	See Note	No	Reconfiguring the windows by means of roi*_configuration* may lead to corrupted frames when configured close to frame boundaries. It is recommended to (re)configure an inactive window and switch the roi_active register. See Notes on roi_active.
<b>Black Calibration</b>			
black_samples	No	No	If configured within range of configured black lines
auto_blackcal_enable	See Note	No	Manual correction factors become instantly active when auto_blackcal_enable is deasserted during operation.
blackcal_offset	See Note	No	Manual blackcal_offset updates are instantly active.
<b>CRC Calculation</b>			
crc_seed	No	No	Impacts the transmitted CRC
<b>Sync Channel</b>			
bl_0	No	No	Impacts the Sync channel information, not the Data channels.
img_0	No	No	Impacts the Sync channel information, not the Data channels.
crc_0	No	No	Impacts the Sync channel information, not the Data channels.
tr_0	No	No	Impacts the Sync channel information, not the Data channels.

## Sensor Status

The currently used exposure and gain parameters are reported by the sensor in registers 240 to 248. These status registers are updated at the start of the frame in which these parameters become active.

## Temperature Diode

The temperature diode allows the monitoring of the sensor die temperature during operation. The diode can be connected through the pins `td_anode` and `td_cathode`.

The die temperature ( $T_{die}$ ), as a function of the measured forward threshold voltage of the diode, with a known bias current ( $V_{diode}$  at bias 40  $\mu A$ ), is determined according to the following formula:

$$T_{die} = (0.77 - V_{diode \text{ at bias } 40 \mu A}) / 0.00158^{\circ}C$$

## Temperature Sensor

The PYTHON has an on-chip temperature sensor which returns a digital code ( $T_{sensor}$ ) of the silicon junction temperature. The  $T_{sensor}$  output is a 8-bit digital count between 0 and 255, proportional to the temperature of the silicon substrate. This reading can be translated directly to a temperature reading in  $^{\circ}C$  by calibrating the 8-bit readout at  $0^{\circ}C$  and  $85^{\circ}C$  to achieve an output accuracy of  $\pm 2^{\circ}C$ . The  $T_{sensor}$  output can also be calibrated using a single temperature point (example: room temperature or the ambient temperature of the application), to achieve an output accuracy of  $\pm 5^{\circ}C$ .

Note that any process variation will result in an offset in the bit count and that offset will remain within  $\pm 5^{\circ}C$  over the temperature range of  $0^{\circ}C$  and  $85^{\circ}C$ .  $T_{sensor}$  output digital code can be read out through the SPI interface.

### Output of the temperature sensor to the SPI:

`tempd_reg_temp<7:0>`: This is the 8-bit N count readout proportional to temperature.

### Input from the SPI:

The `reg_tempd_enable` is a global enable and this enables or disables the temperature sensor when logic high or logic low respectively. The temperature sensor is reset or disabled when the input `reg_tempd_enable` is set to a digital low state.

### Calibration using one temperature point

The temperature sensor resolution is fixed for a given type of package for the operating range of  $0^{\circ}C$  to  $+85^{\circ}C$  and hence devices can be calibrated at any ambient temperature of the application, with the device configured in the mode of operation.

### Interpreting the actual temperature for the digital code readout:

The formula used is

$$T_J = R (N_{read} - N_{calib}) + T_{calib}$$

$T_J$  = junction die temperature

R = resolution in degrees/LSB (typical 0.75 deg/LSB)

$N_{read}$  =  $T_{sensor}$  output (LSB count between 0 and 255)

$T_{calib}$  =  $T_{sensor}$  calibration temperature

$N_{calib}$  =  $T_{sensor}$  output reading at  $T_{calib}$

## Monitor Pins

The sensor features three logic monitor output pins. These pins can provide internal state and synchronization information to the outside system. These status pins can be used during system setup or for system frame synchronization.

The pins are named `monitor0`, `monitor1`, and `monitor2`. The information provided on these pins is configured with the register `monitor_select` (register 192[13:11]).

NOTE: Monitor indications are generated in the sequencer. These signals lead the image and synchronization data on the LVDS channels.



## NOIP1SN025KA, NOIP1SN016KA, NOIP1SN012KA

**Table 16. MONITOR SELECT**

Monitor Select	Monitor Output	Description
0x0	monitor0: '0'	No information is provided on the output pins. All outputs are driven to logic '0'
	monitor1: '0'	
	monitor2: '0'	
0x1	monitor0: Integration time indication	High during integration
	monitor1: ROT indication	High when ROT is active, low outside ROT
	monitor2: Dummy line indication	High during dummy lines, low during all other lines
0x2	monitor0: Integration time indication	High during integration
	monitor1: N/A	N/A
	monitor2: N/A	N/A
0x3	monitor0: Start of X-readout	Pulse indicating the start of X-readout
	monitor1: Black line indication	High during black lines, low during all other lines
	monitor2: Dummy line indication	High during dummy lines, low during all other lines
0x4	monitor0: Frame start	Pulse indicating the start of a new frame
	monitor1: Start of ROT	Pulse indicating the start of ROT
	monitor2: Start of X-readout	Pulse indicating the start of X-readout
0x5	monitor0: First line indication	High during the first line of each frame, low for all others
	monitor1: Start of ROT indication	Pulse indicating the start of ROT
	monitor2: ROT inactive	Low when ROT is active, high outside ROT
0x6	monitor0: ROT indication	High when ROT is active, low outside ROT
	monitor1: Start of X-readout	Pulse indicating the start of X-readout
	monitor2: X-readout inactive	Low during X-readout, high outside X-readout
0x7	monitor0: Start of X-readout for black lines	Pulse indicating the start of X-readout for black lines
	monitor1: Start of X-readout for image lines	Pulse indicating the start of X-readout for image lines
	monitor2: Start of X-readout for dummy lines	Pulse indicating the start of X-readout for dummy lines

## DATA OUTPUT FORMAT

### LVDS Output Channels

The image data output occurs through 32 LVDS data channels, operating at 720 Mbps. A synchronization LVDS channel and an LVDS output clock signal synchronizes the data.

The 32 data channels are used to output the image data only. The sync channel transmits information about data sent over these data channels (includes codes indicating black pixels, normal pixels, and CRC).

To perform word synchronization on the output data stream, a predefined training pattern is sent after startup of the sensor and during idle times (during FOT, ROT, and in between frames and lines). This data is used to perform word alignment on the receiving side.

The words on data and sync channels have a 10-bit length. The words are serialized most significant bit first. The output data rate is 720 Mbps.

### Serial Link Interface Operation

This sensor's serial link interface is based on a mesochronous clocking system. This means that all data and control links operate at the same frequency, but their phase may be different due to skew. The host provides an LVDS clock as input to the sensor. To compensate for possible large on-chip delays, the sensor retransmits this clock with the same delay as that seen by the data (32 data channels) and control path (one sync channel). The receiver end (generally an FPGA-based system) performs per-interface skew compensation.

The data on high-speed serial links can drift due to various reasons such as skew, jitter, PCB trace delays, process, voltage, and temperature variations. The receiver performs per-LVDS interface skew compensation using bit and word alignment techniques.

To support per-interface skew compensation, the sensor provides a training mode that allows the system to perform bit and word alignment on all interfaces.

During idle moments (when the sensor is not capturing images or during frame and line overhead), the image sensor transmits training patterns. These patterns are configurable by means of a register upload and should be chosen such that these can easily be detected by reducing the risk of mimicking in the regular data stream.

#### *Bit Alignment*

Bit alignment procedures position the sampling edge of the clock at the center of the data eye window by adding delay to the data path (using delay taps).

#### *Word Alignment*

Word alignment procedures ensure that the reconstructed parallel data bits are in correct order at the output of the

deserializer. Word alignment is done by looking for well known training patterns.

All major FPGA vendors provide bit and word alignment methods for their FPGAs. Refer to the FPGA vendor's application for more information on the use of these functionalities.

When the host succeeds in a lock for bit and word alignment procedures, the system enables the sensor for image acquisition. Specific frame alignment patterns are transmitted for image frame synchronization purposes.

### Frame Format

The frame format is explained by example of the readout of two (overlapping) windows, as shown in Figure 30 (a).

The readout of a frame occurs on a line-by-line basis. In this representation, the read pointer goes from left to right, bottom to top.

Figure 30 indicates that, after the FOT is complete, a number of lines which only include information of 'ROI 0' are sent out, starting at position  $y0\_start$ . When the line at position  $y1\_start$  is reached, a number of lines containing data of 'ROI 0' and 'ROI 1' are sent out, until the line position of  $y0\_end$  is reached. From there on, only data of 'ROI 1' appears on the data output channels until line position  $y1\_end$  is reached.

NOTE: Only frame start and frame end sync words are indicated in (b). CRC codes are also omitted from Figure 30.

During readout of image data over the data channels, the sync channel sends out frame synchronization codes, which provide information related to the image data being sent over the 32 data output channels.

Each line of a window starts with a line start (LS) indication and ends with a line end (LE) indication. The line start of the first line is replaced by a frame start; the line end of the last line is replaced with a frame end indication. Each such frame synchronization code is followed by a window ID (range 0 to 31).

The data channels contain valid pixel data during FS/FE/LS/LE and window ID synchronization codes.

NOTE: For overlapping windows, the line synchronization codes of the overlapping windows with lower IDs are not sent out. As shown in the illustration, no LE is transmitted for the overlapping part of window 0.

Black lines are read out at the start of a frame. These lines are enclosed by LS and LE indications (no frame start/end). The window ID for the black lines must be ignored.

NOIP1SN025KA, NOIP1SN016KA, NOIP1SN012KA



Figure 30. Frame Sync Codes

Figure 31 and Figure 32 show the details of the readout of a number of lines for single window readout, at the beginning of the frame.

Figure 33 shows the details of the readout of a number of lines for two overlapping windows.



Figure 31. Timeline Showing Readout of Black Line for Global Shutter

# NOIP1SN025KA, NOIP1SN016KA, NOIP1SN012KA

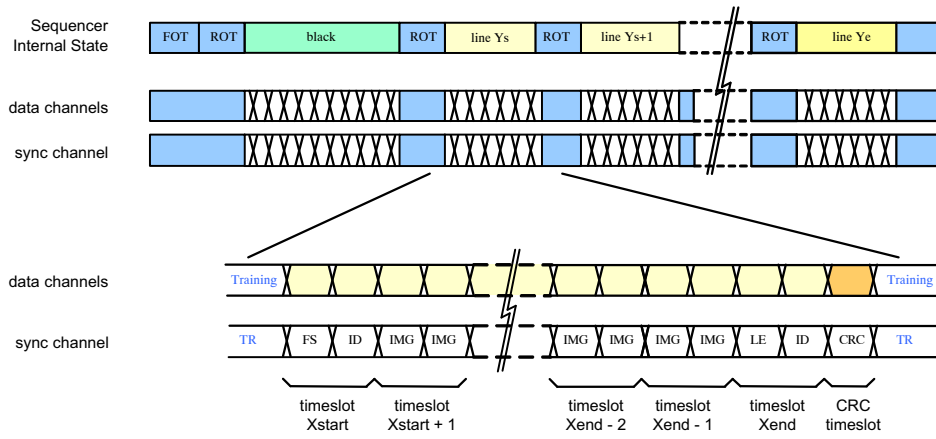

**Figure 32. Timeline for Single Window Readout**

NOTE: In the figure, the second image line is shown in more detail. The LS code is replaced by FS for the first line and the LE code is replaced by FE for the last line in the window.

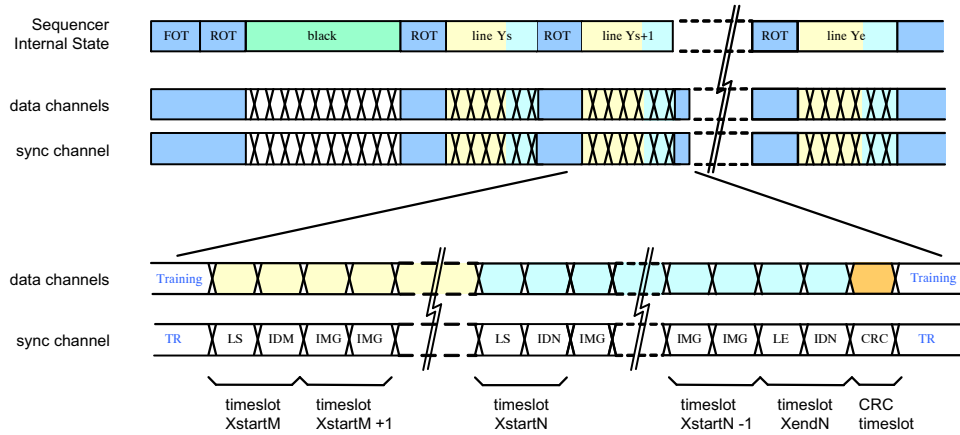

**Figure 33. Timeline Showing Readout of Two Overlapping Windows**

## NOIP1SN025KA, NOIP1SN016KA, NOIP1SN012KA

### Frame Synchronization

Table 17 shows the structure of the frame synchronization code. Note that the table shows the default data word (configurable). If more than one window is active at the

same time, the sync channel transmits the frame synchronization codes of the window with highest index only.

**Table 17. FRAME SYNCHRONIZATION CODE DETAILS**

Sync Word Bit Position	Register Address	Default Value	Description
9:7	N/A	0x5	Frame start (FS) indication
9:7	N/A	0x6	Frame end (FE) indication
9:7	N/A	0x1	Line start (LS) indication
9:7	N/A	0x2	Line end (LE) indication
6:0	117[6:0]	0x2A	These bits indicate that the received sync word is a frame synchronization code. The value is programmable by a register setting

### Window Identification

Frame synchronization codes are always followed by a 4-bit window identification (bits 3:0). This is an integer number, ranging from 0 to 15, indicating the active window. If more than one window is active for the current cycle, the highest window ID is transmitted.

### Data Classification Codes

For the remaining cycles, the sync channel indicates the type of data sent through the data links: black pixel data (BL), image data (IMG), or training pattern (TR). These codes are programmable by a register setting. The default values are listed in Table 18.

**Table 18. SYNCHRONIZATION CHANNEL DEFAULT IDENTIFICATION CODE VALUES**

Sync Word Bit Position	Register Address	Default Value	Description
9:0	118 [9:0]	0x015	Black pixel data (BL). This data is not part of the image. The black pixel data is used internally to correct channel offsets.
9:0	119 [9:0]	0x035	Valid pixel data (IMG). The data on the data output channels is valid pixel data (part of the image).
9:0	125 [9:0]	0x059	CRC value. The data on the data output channels is the CRC code of the finished image data line.
9:0	126 [9:0]	0x3A6	Training pattern (TR). The sync channel sends out the training pattern which can be programmed by a register setting.

**Training Patterns on Data Channels**

During idle periods, the data channels transmit training patterns, indicated on the sync channel by a TR code. These

training patterns are configurable independent of the training code on the sync channel as shown in Table 19.

**Table 19. TRAINING CODE ON SYNC CHANNEL**

Sync Word Bit Position	Register Address	Default Value	Description
[9:0]	116 [9:0]	0x3A6	Data channel training pattern. The data output channels send out the training pattern, which can be programmed by a register setting. The default value of the training pattern is 0x3A6, which is identical to the training pattern indication code on the sync channel.

**Cyclic Redundancy Code**

At the end of each line, a CRC code is calculated to allow error detection at the receiving end. Each data channel transmits a CRC code to protect the data words sent during the previous cycles. Idle and training patterns are not included in the calculation.

The sync channel is not protected. A special character (CRC indication) is transmitted whenever the data channels send their respective CRC code.

The polynomial is  $x^{10}+x^9+x^6+x^3+x^2+x+1$ . The CRC encoder is seeded at the start of a new line and updated for every (valid) data word received. The CRC seed is configurable using the `crc_seed` register. When '0', the CRC is seeded by all-'0'; when '1' it is seeded with all-'1'.

**NOTE:** Note The CRC is calculated for every line. This implies that the CRC code can protect lines from multiple windows.

**Black Reference**

The sensor reads out one or more black lines at the start of every new frame. The number of black lines to be generated is programmable and is at a minimum, equal to 1. The length of the black lines depends on the operation mode. For global shutter mode, the sensor always reads out the entire line, independent of window configurations.

The black references are used to perform black calibration and offset compensation in the data channels. The raw black pixel data is transmitted over the usual LVDS channels, while the regular image data is compensated (can be bypassed).

On the output interface, black lines can be seen as a separate window, without frame start and ends (only line start and ends). The window ID is to be ignored and data is indicated by a BL code.

# NOIP1SN025KA, NOIP1SN016KA, NOIP1SN012KA

## Example Using Multiple Windowing

Figure 34 shows an example of the synchronization codes sent when reading out multiple windows.



Figure 34. Synchronization Codes for Multiple Windows (applicable for Global Shutter only)

**LVDS Output Multiplexing**

The PYTHON sensor contains a function for down-multiplexing the output channels. Using this function, one may for instance use the PYTHON XK with 16, 8 or 4 datachannels instead of 32 data channels.

Enabling the down-multiplexing is done through the muxmode[1:0] pins. Connecting these pins to ground disables all down-multiplexing. Configuring higher values sets a higher degree of down-multiplexing. The channels that are used per degree of multiplexing are shown in Table 20. The unused data channels are powered down and will not send any data.

Note the maximum frequency for the SPI interface needs to scale with the amount of LVDS channels as described in Table 5.

**Table 20. LVDS CHANNEL MULTIPLEXING**

No. of LVDS outputs	Channels Multiplexed	Output Channel	No. of Repetition of Sync Codes
32	No multiplexing	Ch0 to Ch31	1
16	Ch0, Ch1	Ch0	2
	Ch2, Ch3	Ch2	
	Ch4, Ch5	Ch4	
	Ch6, Ch7	Ch6	
	Ch8, Ch9	Ch8	
	Ch10, Ch11	Ch10	
	Ch12, Ch13	Ch12	
	Ch14, Ch15	Ch14	
	Ch16, Ch17	Ch16	
	Ch18, Ch19	Ch18	
	Ch20, Ch21	Ch20	
	Ch22, Ch23	Ch22	
	Ch24, Ch25	Ch24	
	Ch26, Ch27	Ch26	
	Ch28, Ch29	Ch28	
	Ch30, Ch31	Ch30	

8	Ch0, Ch1, Ch2, Ch3	Ch0	4
	Ch4, Ch5, Ch6, Ch7	Ch4	
	Ch8, Ch9, Ch10, Ch11	Ch8	
	Ch12, Ch13, Ch14, Ch15	Ch12	
	Ch16, Ch17, Ch18, Ch19	Ch16	
	Ch20, Ch21, Ch22, Ch23	Ch20	
	Ch24, Ch25, Ch26, Ch27	Ch24	
	Ch28, Ch29, Ch30, Ch31	Ch28	
4	Ch0, Ch1, Ch2, Ch3, Ch4, Ch5, Ch6, Ch7	Ch0	8
	Ch8, Ch9, Ch10, Ch11, Ch12, Ch13, Ch14, Ch15	Ch8	
	Ch16, Ch17, Ch18, Ch19, Ch20, Ch21, Ch22, Ch23	Ch16	
	Ch24, Ch25, Ch26, Ch27, Ch28, Ch29, Ch30, Ch31	Ch24	

Table 21 shows how to select the desired output multiplex mode and describes the required register upload needed to guarantee the correct functionality of the sensor.

**Table 21. OUTPUT MULTIPLEX MODE SELECTION**

muxmode1 (Pin F24)	muxmode0 (Pin F25)	Number of Output LVDS Channels	Required Upload	
			Address	Data
0	0	32	211	0x0E5B
0	3.3 V	16	211	0x0E4B
3.3 V	0	8	211	0x0E3B
3.3 V	3.3 V	4	211	0x0E2B



# NOIP1SN025KA, NOIP1SN016KA, NOIP1SN012KA

## Data Order

To read out the image data through the output channels, the pixel array is organized in kernels. The kernel size is 64 pixels in x-direction by one pixel in y-direction.

Figure 35 indicates how the kernels are organized. The data order of this image data on the data output channels depends on the subsampling mode.

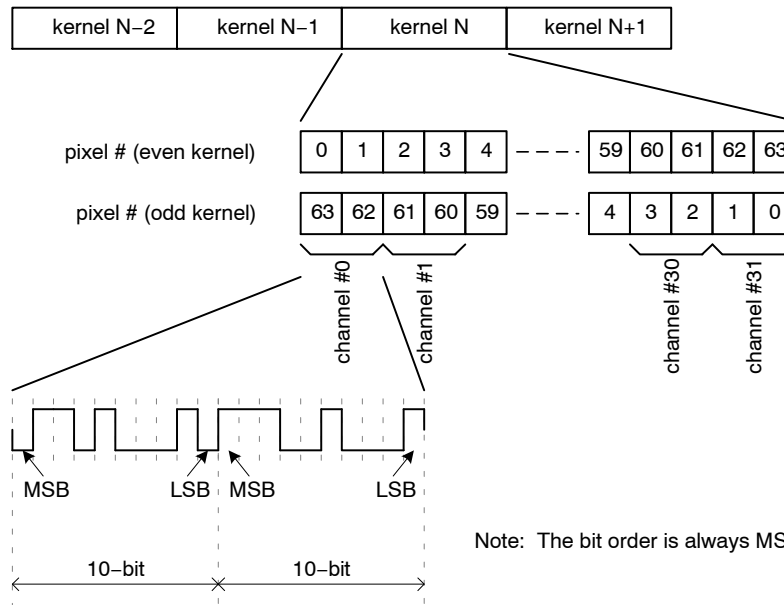

**Figure 35. Kernel Organization in Pixel Array**

- P1-SE/SN/FN: Subsampling Disabled
  - ◆ 32 LVDS Output Channels

The image data is read out in kernels of 64 pixels in x-direction by one pixel in y-direction. One data channel output delivers two pixel values of one kernel sequentially.

Figure 36 shows how a kernel is read out over the 32 output channels. For even positioned kernels, the kernels are read out ascending, and for odd positioned kernels the data order is reversed (descending).



Note: The bit order is always MSB first

**Figure 36. 32 LVDS Data Output Order when Subsampling is Disabled**

- ◆ 16 LVDS Output Channels

Figure 37 shows how a kernel is read out over the 16 output channels. Each pair of adjacent channels is multiplexed into one channel. For even positioned kernels,

the kernels are read out ascending but in pair of even and odd pixels, while for odd positioned kernels the data order is reversed (descending) but in pair of even and odd pixels.

## NOIP1SN025KA, NOIP1SN016KA, NOIP1SN012KA



**Figure 37. Data Output Order for 16 LVDS Outputs when Subsampling is Disabled**

◆ 8 LVDS Output Channels

Figure 38 shows how a kernel is read out over the 8 output channels. Each bunch of four adjacent channels is multiplexed into one channel. For even positioned kernels,

the kernels are read out ascending but in sets of 4 even and 4 odd pixels, while for odd positioned kernels the data order is reversed (descending) but in sets of 4 odd and 4 even pixels.



**Figure 38. Data Output Order for 8 LVDS Outputs when Subsampling is Disabled**

◆ 4 LVDS Output Channels

Figure 39 shows how a kernel is read out over the 4 output channels. Each bunch of eight adjacent channels is multiplexed into one channel. For even positioned kernels,

the kernels are read out ascending but in sets of 8 even and 8 odd pixels, while for odd positioned kernels the data order is reversed (descending) but in sets of 8 odd and 8 even pixels.

# NOIP1SN025KA, NOIP1SN016KA, NOIP1SN012KA



**Figure 39. Data Output Order for 4 LVDS Outputs when Subsampling is Disabled**

- **Subsampling on Monochrome Sensors**

During subsampling, every other pixel is read out and the lines are read in a read-1-skip-1 manner. To read out the image data with subsampling enabled, two neighboring kernels are combined to a single kernel of 128 pixels in the x-direction and one pixel in the y-direction.

Note that there is no difference in data order for even and odd kernel numbers. This is opposed to the ‘no-subsampling’ readout described earlier.

- ♦ **32 LVDS Output Channels**

Figure 40 shows the data order for 32 LVDS output channels.

Note that there is no difference in data order for even/odd kernel numbers, as opposed to the ‘no-subsampling’ readout described in section 0.

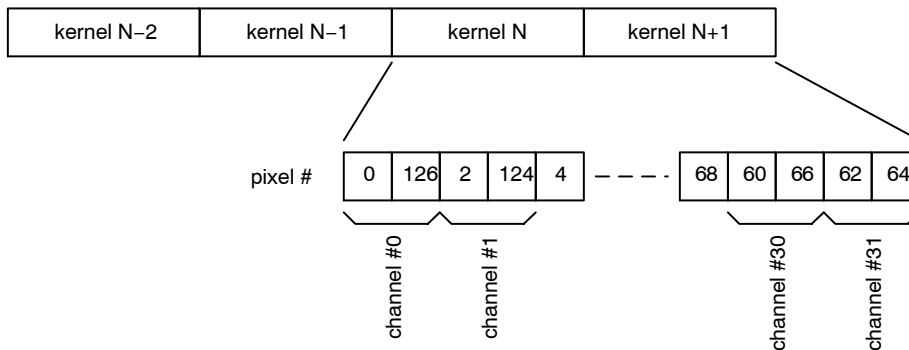

**Figure 40. Data Output Order for 32 LVDS Output Channels in Subsampling Mode on a Monochrome Sensor**

## NOIP1SN025KA, NOIP1SN016KA, NOIP1SN012KA

### ◆ 16 LVDS Output Channels

Figure 41 shows the data order for 16 LVDS output channels.

Note that there is no difference in data order for even/odd kernel numbers, as opposed to the 'no-subsampling' readout described in section 0.

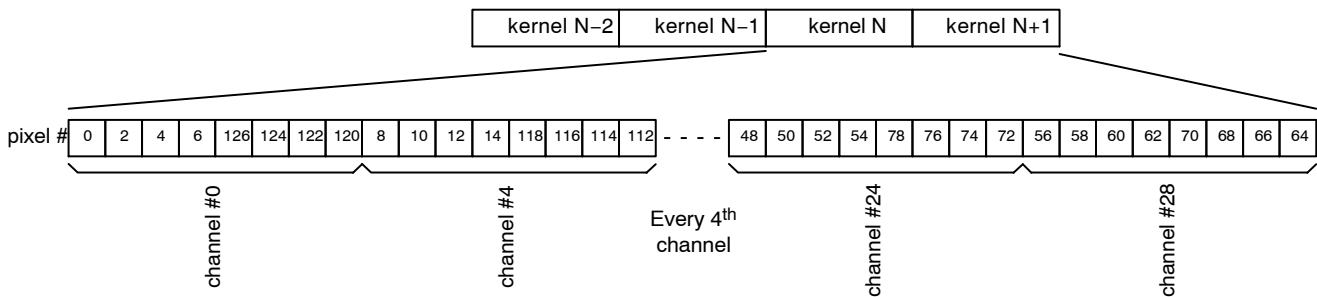

**Figure 41. Data Output Order for 16 LVDS Output Channels in Subsampling Mode on a Monochrome Sensor**

### ◆ 8 LVDS Output Channels

Figure 42 shows the data order for 8 LVDS output channels.

Note that there is no difference in data order for even/odd kernel numbers, as opposed to the 'no-subsampling' readout described in section 0.

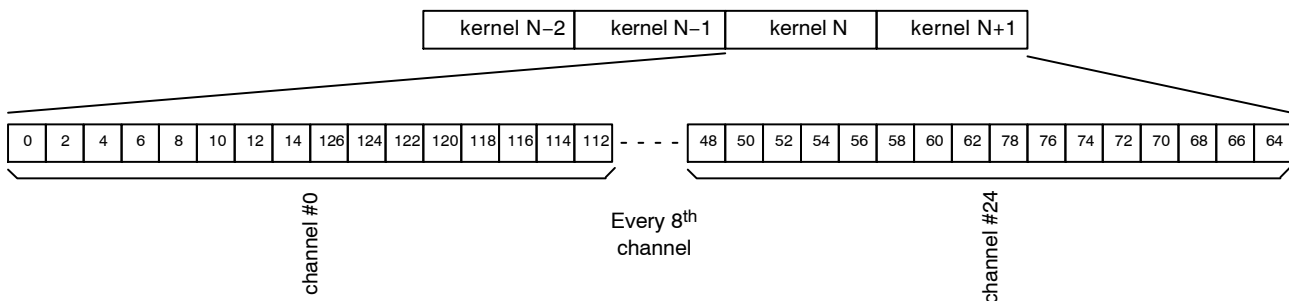

**Figure 42. Data Output Order for 8 LVDS Output Channels in Subsampling Mode on a Monochrome Sensor**

### ◆ 4 LVDS Output Channels

Figure 43 shows the data order for 4 LVDS output channels.

Note that there is no difference in data order for even/odd kernel numbers, as opposed to the 'no-subsampling' readout described in section 0.



**Figure 43. Data Output Order for 4 LVDS Output Channels in Subsampling Mode on a Monochrome Sensor**

### ● Subsampling on Color Sensor

To read out the image data with subsampling enabled on a color sensor, two neighboring kernels are combined to a single kernel of 128 pixels in the x-direction and 1 pixel in the y-direction. Only the pixels 0, 1, 4, 5, 8, 9, 12, 13 to 124, and 125 are read out. There is no difference in data order for

even/odd kernel numbers, as opposed to the 'no-subsampling' readout described in section.

### ◆ 32 LVDS Output Channels

Figure 44 shows the data order for 32 LVDS output channels.

## NOIP1SN025KA, NOIP1SN016KA, NOIP1SN012KA



**Figure 44. Data Output Order for 32 LVDS Output Channels in Subsampling Mode on a Color Sensor**

◆ 16 LVDS Output Channels

Figure 45 shows the data order for 16 LVDS output channels.

Note that there is no difference in data order for even/odd kernel numbers, as opposed to the ‘no-subsampling’ readout described in section 0.



**Figure 45. Data Output Order for 16 LVDS Output Channels in Subsampling Mode on a Color Sensor**

◆ 8 LVDS Output Channels

Figure 46 shows the data order for 8 LVDS output channels.

Note that there is no difference in data order for even/odd kernel numbers, as opposed to the ‘no-subsampling’ readout described in section 0.



**Figure 46. Data Output Order for 8 LVDS Output Channels in Subsampling Mode on a Color Sensor**

◆ 4 LVDS Output Channels

Figure 47 shows the data order for 4 LVDS output channels.

Note that there is no difference in data order for even/odd kernel numbers, as opposed to the ‘no-subsampling’ readout described in section 0.

## NOIP1SN025KA, NOIP1SN016KA, NOIP1SN012KA



**Figure 47. Data Output Order for 4 LVDS Output Channels in Subsampling Mode on a Color Sensor**

### Frame Rate

Frame rate for subsampling mode is compared to the normal mode. Assume the y-resolution is the programmed number of lines to read out.

#### Normal Readout

The frame time in normal readout mode is shown by the following formula:

$$\text{Frame Time} = t_{\text{FOT}} + (\text{y-resolution}) \times (t_{\text{ROT}} + t_{\text{readout}})$$

The frame rate is equal to  $1/\text{FrameTime}$ . Nominal frame rate for full frame readout is 80 fps in Zero-ROT mode.

#### Subsampling Mode

The frame time for subsampled readout is shown by the following formula:

$$\text{Frame Time} = t_{\text{FOT}} + (\text{y-resolution} / 2) \times (t_{\text{ROT}} + t_{\text{readout}} / 2),$$

where  $t_{\text{ROT}}$  represents the equivalent ROT time for a normal readout of the same frame. Analogous readout represents the equivalent readout time for normal readout.

The frame time for subsampled readout is given by the following formula:

$$\text{Frame Time} = t_{\text{FOT}} + (\text{y-resolution} / 2) \times (t_{\text{ROT}} \times 2 + t_{\text{readout}} / 2),$$

where  $t_{\text{ROT}}$  represents the equivalent ROT time for a normal readout of the same frame. Analogous readout represents the equivalent readout time for normal readout.

### Test Pattern Generation

The data block provides several test pattern generation capabilities. Figure 48 shows the functional diagram for the data channels. It is possible to inject synthesized test patterns at various points. Refer to the Register Map on page 48 for the test mode configuration registers (registers 144 to 150).

The test pattern modes are summarized in Table 22. Note that these modes only exist for the data channel. The sync and clock channels do not provide this functionality.

For each test mode, the user can select whether the generated data is framed. When the register `frame_testpattern` is asserted, the test data simply replaces the ADC data. This means that the test data is only sent between frame/line start and frame/line end indications. Outside these windows, regular training patterns are sent, as during normal operation. CRC is calculated and inserted as for normal data for the fixed and incrementing test pattern generation.

**Table 22. TEST MODE SUMMARY**

Register Configuration			Description
<code>prbs_en</code>	<code>testpattern_en</code>	<code>testpattern</code>	
0	0	X	Normal operation mode
0	1	0	Fixed pattern generation. Pattern is defined by <code>testpattern</code> register
0	1	1	Incrementing pattern generation. Initial value is determined by <code>testpattern</code> .
1	X	X	PRBS data generation. The <code>testpattern</code> register determines the seed for the PRBS generator.

When `frame_testpattern` is deasserted, the output is constantly replaced by the generated test data. No training patterns are generated.

## NOIP1SN025KA, NOIP1SN016KA, NOIP1SN012KA



**Figure 48. Functional Block Diagrams for the Data Channels**

NOTE: In the figure, register configurations are indicated in red.

The sync channel continues to send regular frame timing information when the sequencer is enabled (independently of the test pattern configurations).

The synthesized test patterns are injected directly into the data channels. Therefore, no data demultiplexing is required at the receiving end (as opposed to regular image data capture).

### *Fixed Pattern*

A configured word can be continuously repeated on the output. This word is configurable for each data channel separately (testpattern). The testpattern is inserted when testpattern\_en is asserted.

### *Incrementing Test Pattern*

In each cycle, the test pattern word is incremented by one, when inc\_testpattern is asserted. After reaching the maximum value, the incrementer is reset to its start value (testpattern). When the testdata is framed, the incrementer is also reset to the testpattern value at each line start.

To enable this mode, enable the digital testpattern mode (assert testpattern\_en) and assert inc\_testpattern.

### *Pseudo Random Bit Sequence Generation*

In this test mode, the output channels are sourced with pseudo random bit sequence (PRBS) pattern. The PRBS seed can be configured for each data channel using the testpattern register. For the other test pattern generation mode, the datastream is not interrupted when frame\_testpattern is deasserted.

### NOTES:

- The CRC generator is not functional in this mode, and no real CRC can be calculated. Instead, the CRC slot is used to send one more PRBS word.
- A PRBS generator does not generate random data when the seed is all zero. Therefore, it is advisable to configure the testpattern registers to a value different from '0'. Using different seeds for each channel results in different sequences for each data channel.

# NOIP1SN025KA, NOIP1SN016KA, NOIP1SN012KA

## REGISTER MAP

Each functional entity has a dedicated address space, starting at a block offset. The register address is obtained by adding the address offset to the block offset. This address must be used to perform SPI uploads and is shown in the Address column of the register map table.

The table below represents the register map for the NOIP1xx025KA part. Deviating default values for the NOIP1xx16KA and NOIP1xx12KA are mentioned between brackets (“[]”).

**Table 23. REGISTER MAP**

Category	Block Offset	Address Offset	Address	Bit Field	Register Name	Default (Hex)	Default	Description	Type
Chip ID	0								
		0	0		chip_id	0x50FA	20730	Chip ID	Status
				[15:0]	id	0x50FA	20730	Chip ID	
		1	1		reserved	0x0000	0	Reserved	Status
				[3:0]	reserved	0x0	0	Reserved	
				[9:8]	resolution	0x0	0	P25K: 0, P16K: 1, P12K: 2	
				[11:10]	reserved	0x0	0	Reserved	
		2	2		chip_configuration	0x0000	0	Chip General Configuration	RW
				[0]	color	0x0	0	Color/Monochrome Configuration '0': Monochrome '1': Color	
				[1]	reserved	0x0	0	Reserved	
				[15:2]	reserved	0x0	0	Reserved	
Reset Generator	8								
		0	8		reserved	0x0099	153	Reserved	RW
				[3:0]	reserved	0x9	9	Reserved	
				[7:4]	reserved	0x9	9	Reserved	
		1	9		reserved	0x0009	9	Reserved	RW
				[3:0]	reserved	0x9	9	Reserved	
		2	10		reserved	0x0999	2457	Reserved	RW
				[3:0]	reserved	0x9	9	Reserved	
				[7:4]	reserved	0x9	9	Reserved	
				[11:8]	reserved	0x9	9	Reserved	
	16				reserved			Reserved	
		0	16		reserved	0x0004	4	Reserved	RW
				[0]	reserved	0x0	0	Reserved	
				[1]	reserved	0x0	0	Reserved	
				[2]	reserved	0x1	1	Reserved	
		1	17		reserved	0x2113	8467	Reserved	RW
				[7:0]	reserved	0x13	19	Reserved	
				[12:8]	reserved	0x1	1	Reserved	
				[14:13]	reserved	0x1	1	Reserved	
	20				reserved			Reserved	
		0	20		reserved	0x0000	0	Reserved	RW
				[0]	reserved	0x0	0	Reserved	
				[9:8]	reserved	0x0	0	Reserved	
				[10]	reserved	0x0	0	Reserved	
	24				reserved			Reserved	
		0	24		reserved	0x0000	0	Reserved	Status
				[0]	reserved	0x0	0	Reserved	



## NOIP1SN025KA, NOIP1SN016KA, NOIP1SN012KA

**Table 23. REGISTER MAP**

Category	Block Offset	Address Offset	Address	Bit Field	Register Name	Default (Hex)	Default	Description	Type
		2	26		reserved	0x2280	8832	Reserved	RW
				[7:0]	reserved	0x80	128	Reserved	
				[10:8]	reserved	0x2	2	Reserved	
				[14:12]	reserved	0x2	2	Reserved	
		3	27		reserved	0x3D2D	15661	Reserved	RW
				[7:0]	reserved	0x2D	45	Reserved	
				[15:8]	reserved	0x3D	61	Reserved	
Clock Generator	32								
		0	32		config0	0x0004	4	Clock Generator Configuration	RW
				[0]	enable_analog	0x0	0	Enable analogue clocks '0': disabled, '1': enabled	
				[1]	reserved	0x0	0	Reserved	
				[2]	reserved	0x1	1	Reserved	
				[3]	reserved	0x0	0	Reserved	
				[5:4]	mux	0x0	0	Multiplex Mode	
				[11:8]	reserved	0x0	0	Reserved	
				[14:12]	reserved	0x0	0	Reserved	
General Logic	34								
		0	34		config0	0x0000	0	Clock Generator Configuration	RW
				[0]	enable	0x0	0	Logic General Enable Configuration '0': Disable '1': Enable	
	38	0	38		reserved	0x0000	0	Reserved	RW
				[15:0]	reserved	0x0000	0	Reserved	
		1	39		reserved	0x0000	0	Reserved	RW
				[15:0]	reserved	0x0000	0	Reserved	
Image Core	40								
		0	40		image_core_config0	0x0000	0	Image Core Configuration	RW
				[0]	imc_pwd_n	0x0	0	Image Core Power Down '0': powered down, '1': powered up	
				[1]	mux_pwd_n	0x0	0	Column Multiplexer Power Down '0': powered down, '1': powered up	
				[2]	colbias_enable	0x0	0	Bias Enable '0': disabled '1': enabled	
		1	41		reserved	0x0B5A	2906	Reserved	RW
				[3:0]	reserved	0xA	10	Reserved	
				[7:4]	reserved	0x5	5	Reserved	
				[10:8]	reserved	0x3	3	Reserved	
				[12:11]	reserved	0x1	1	Reserved	
				[13]	reserved	0x0	0	Reserved	
				[14]	reserved	0x0	0	Reserved	
				[15]	reserved	0x0	0	Reserved	
		2	42		reserved	0x0001	1	Reserved	RW

**NOIP1SN025KA, NOIP1SN016KA, NOIP1SN012KA**

**Table 23. REGISTER MAP**

Category	Block Offset	Address Offset	Address	Bit Field	Register Name	Default (Hex)	Default	Description	Type
				[0]	reserved	0x1	1	Reserved	
				[1]	reserved	0x0	0	Reserved	
				[6:4]	reserved	0x0	0	Reserved	
				[10:8]	reserved	0x0	0	Reserved	
				[15:12]	reserved	0x0	0	Reserved	
		3	43		reserved	0x0000	0	Reserved	RW
				[0]	reserved	0x0	0	Reserved	
				[1]	reserved	0x0	0	Reserved	
				[2]	reserved	0x0	0	Reserved	
				[3]	reserved	0x0	0	Reserved	
				[6:4]	reserved	0x0	0	Reserved	
				[7]	reserved	0x0	0	Reserved	
				[15:8]	reserved	0x0	0	Reserved	
AFE	48								
		0	48		power_down	0x0000	0	AFE Configuration	RW
				[0]	pwd_n	0x0	0	Power down for AFE's '0': powered down, '1': powered up	
Bias	64								
		0	64		power_down	0x0000	0	Bias Power Down Configuration	RW
				[0]	pwd_n	0x0	0	Power down bandgap '0': powered down, '1': powered up	
		1	65		configuration	0x888B	34955	Bias Configuration	RW
				[0]	extres	0x1	1	External Resistor Selection '0': internal resistor, '1': external resistor	
				[3:1]	reserved	0x5	5	Reserved	
				[7:4]	reserved	0x8	8	Reserved	
				[11:8]	reserved	0x8	8	Reserved	
				[15:12]	reserved	0x8	8	Reserved	
		2	66		reserved	0x53C8	21448	Reserved	RW
				[3:0]	reserved	0x8	8	Reserved	
				[7:4]	reserved	0xC	12	Reserved	
				[14:8]	reserved	0x53	83	Reserved	
		3	67		reserved	0x8888	34952	Reserved	RW
				[3:0]	reserved	0x8	8	Reserved	
				[7:4]	reserved	0x8	8	Reserved	
				[11:8]	reserved	0x8	8	Reserved	
				[15:12]	reserved	0x8	8	Reserved	
		4	68		lvds_bias	0x0088	136	LVDS Bias Configuration	RW
				[3:0]	lvds_ibias	0x8	8	LVDS Ibias	
				[7:4]	lvds_iref	0x8	8	LVDS Iref	
		5	69		reserved	0x0888	2184	Reserved	RW
				[3:0]	reserved	0x8	8	Reserved	
				[7:4]	reserved	0x8	8	Reserved	
				[11:8]	reserved	0x8	8	Reserved	
		6	70		reserved	0x8888	34952	Reserved	RW
				[3:0]	reserved	0x8	8	Reserved	

**NOIP1SN025KA, NOIP1SN016KA, NOIP1SN012KA**

**Table 23. REGISTER MAP**

Category	Block Offset	Address Offset	Address	Bit Field	Register Name	Default (Hex)	Default	Description	Type
				[7:4]	reserved	0x8	8	Reserved	
				[11:8]	reserved	0x8	8	Reserved	
				[15:12]	reserved	0x8	8	Reserved	
		7	71		reserved	0x8888	34952	Reserved	RW
				[15:0]	reserved	0x8888	34952	Reserved	
	72				reserved			Reserved	
		0	72		reserved	0x2220	8736	Reserved	RW
				[0]	reserved	0x0	0	Reserved	
				[1]	reserved	0x0	0	Reserved	
				[2]	reserved	0x0	0	Reserved	
				[6:4]	reserved	0x2	2	Reserved	
				[10:8]	reserved	0x2	2	Reserved	
				[14:12]	reserved	0x2	2	Reserved	
	80				reserved			Reserved	
		0	80		reserved	0x0000	0	Reserved	RW
				[1:0]	reserved	0x0	0	Reserved	
				[3:2]	reserved	0x0	0	Reserved	
				[5:4]	reserved	0x0	0	Reserved	
				[7:6]	reserved	0x0	0	Reserved	
				[9:8]	reserved	0x0	0	Reserved	
		1	81		reserved	0x8881	34945	Reserved	RW
				[15:0]	reserved	0x8881	34945	Reserved	
Temperature Sensor	96								
		0	96		enable	0x0000	0	Temperature Sensor Configuration	RW
				[0]	enable	0x0	0	Temperature Diode Enable '0': disabled, '1': enabled	
				[1]	reserved	0x0	0	Reserved	
				[2]	reserved	0x0	0	Reserved	
				[3]	reserved	0x0	0	Reserved	
				[4]	reserved	0x0	0	Reserved	
				[5]	reserved	0x0	0	Reserved	
				[13:8]	offset	0x0	0	Temperature Offset (signed)	
		1	97		temp	0x0000	0	Temperature Sensor Status	Status
				[7:0]	temp	0x00	0	Temperature Readout	
	104				reserved			Reserved	
		0	104		reserved	0x0000	0	Reserved	RW
				[15:0]	reserved	0x0	0	Reserved	
		1	105		reserved	0x0000	0	Reserved	RW
				[1:0]	reserved	0x0	0	Reserved	
				[6:2]	reserved	0x0	0	Reserved	
				[7]	reserved	0x0	0	Reserved	
				[9:8]	reserved	0x0	0	Reserved	
				[14:10]	reserved	0x0	0	Reserved	
				[15]	reserved	0x0	0	Reserved	
		2	106		reserved	0x0000	0	Reserved	Status

## NOIP1SN025KA, NOIP1SN016KA, NOIP1SN012KA

**Table 23. REGISTER MAP**

Category	Block Offset	Address Offset	Address	Bit Field	Register Name	Default (Hex)	Default	Description	Type
				[15:0]	reserved	0x0000	0	Reserved	
		3	107		reserved	0x0000	0	Reserved	Status
				[15:0]	reserved	0x0000	0	Reserved	
		4	108		reserved	0x0000	0	Reserved	Status
				[15:0]	reserved	0x0000	0	Reserved	
		5	109		reserved	0x0000	0	Reserved	Status
				[15:0]	reserved	0x0000	0	Reserved	
		6	110		reserved	0x0000	0	Reserved	Status
				[15:0]	reserved	0x0000	0	Reserved	
		7	111		reserved	0x0000	0	Reserved	Status
				[15:0]	reserved	0x0000	0	Reserved	
Serializers/ LVDS/IO	112								
		0	112		power_down	0x0000	0	LVDS Power Down Configuration	RW
				[0]	clock_out_pwd_n	0x0	0	Power down for Clock Output. '0': powered down, '1': powered up	
				[1]	sync_pwd_n	0x0	0	Power down for Sync channel '0': powered down, '1': powered up	
				[2]	data_pwd_n	0x0	0	Power down for data channels (4 channels) '0': powered down, '1': powered up	
Sync Words	116	4	116		trainingpattern	0x03A6	934	Data Formatting – Training Pattern	RW
				[9:0]	trainingpattern	0x3A6	934	Training pattern sent on Data channels during idle mode. This data is used to perform word alignment on the LVDS data channels.	
		5	117		sync_code0	0x002A	42	LVDS Power Down Configuration	RW
				[6:0]	frame_sync_0	0x02A	42	Frame Sync Code LSBs – Even kernels	
		6	118		sync_code1	0x0015	21	Data Formatting – BL Indication	RW
				[9:0]	bl_0	0x015	21	Black Pixel Identification Sync Code – Even kernels	
		7	119		sync_code2	0x0035	53	Data Formatting – IMG Indication	RW
				[9:0]	img_0	0x035	53	Valid Pixel Identification Sync Code – Even kernels	
		8	120		sync_code3	0x0025	37	Data Formatting – IMG Indication	RW
				[9:0]	ref_0	0x025	37	Reference Pixel Identification Sync Code – Even kernels	
		9	121		sync_code4	0x002A	42	LVDS Power Down Configuration	RW
				[6:0]	frame_sync_1	0x02A	42	Frame Sync Code LSBs – Odd kernels	
		10	122		sync_code5	0x0015	21	Data Formatting – BL Indication	RW

## NOIP1SN025KA, NOIP1SN016KA, NOIP1SN012KA

**Table 23. REGISTER MAP**

Category	Block Offset	Address Offset	Address	Bit Field	Register Name	Default (Hex)	Default	Description	Type
				[9:0]	bl_1	0x015	21	Black Pixel Identification Sync Code – Odd kernels	
		11	123		sync_code6	0x0035	53	Data Formatting – IMG Indication	RW
				[9:0]	img_1	0x035	53	Valid Pixel Identification Sync Code – Odd kernels	
		12	124		sync_code7	0x0025	37	Data Formatting – IMG Indication	RW
				[9:0]	ref_1	0x025	37	Reference Pixel Identification Sync Code – Odd kernels	
		13	125		sync_code8	0x0059	89	Data Formatting – CRC Indication	RW
				[9:0]	crc	0x059	89	CRC Value Identification Sync Code	
		14	126		sync_code9	0x03A6	934	Data Formatting – TR Indication	RW
				[9:0]	tr	0x3A6	934	Training Value Identification Sync Code	
		15	127		reserved	0x02AA	682	Reserved	RW
				[9:0]	reserved	0x2AA	682	Reserved	
Data Block	128								
		0	128		blackcal	0x4008	16392	Black Calibration Configuration	RW
				[7:0]	black_offset	0x08	8	Desired black level at output	
				[10:8]	black_samples	0x0	0	Black pixels taken into account for black calibration. Total samples = 2**black_samples	
				[14:11]	reserved	0x8	8	Reserved	
				[15]	crc_seed	0x0	0	CRC Seed '0': All-0 '1': All-1	
		1	129		general_configuration	0x0001	1	Black Calibration and Data Formatting Configuration	RW
				[0]	auto_blackcal_enable	0x1	1	Automatic blackcalibration is enabled when 1, bypassed when 0	
				[9:1]	blackcal_offset	0x00	0	Black Calibration offset used when auto_black_cal_en = '0'.	
				[10]	blackcal_offset_dec	0x0	0	blackcal_offset is added when 0, subtracted when 1	
				[11]	reserved	0x0	0	Reserved	
				[12]	reserved	0x0	0	Reserved	
				[13]	reserved	0x0	0	Reserved	
				[14]	ref_mode	0x0	0	Data contained on reference lines: '0': reference pixels '1': black average for the corresponding data channel	
				[15]	ref_bcal_enable	0x0	0	Enable black calibration on reference lines '0': Disabled '1': Enabled	

**NOIP1SN025KA, NOIP1SN016KA, NOIP1SN012KA**

**Table 23. REGISTER MAP**

Category	Block Offset	Address Offset	Address	Bit Field	Register Name	Default (Hex)	Default	Description	Type
		2	130		reserved	0x000F	15	Reserved	RW
				[0]	reserved	0x1	1	Reserved	
				[1]	reserved	0x1	1	Reserved	
				[2]	reserved	0x1	1	Reserved	
				[3]	reserved	0x1	1	Reserved	
				[4]	reserved	0x0	0	Reserved	
				[8]	reserved	0x0	0	Reserved	
		8	136		blackcal_error0	0x0000	0	Black Calibration Status	Status
				[15:0]	blackcal_error[15:0]	0x0000	0	Black Calibration Error. This flag is set when not enough black samples are available. Black Calibration shall not be valid. Channels 0–16	
		9	137		blackcal_error1	0x0000	0	Black Calibration Status	Status
				[15:0]	blackcal_error[31:16]	0x0000	0	Black Calibration Error. This flag is set when not enough black samples are available. Black Calibration shall not be valid. Channels 16–31	
		10	138		blackcal_error2	0x0000	0	Black Calibration Status	Status
				[15:0]	blackcal_error[47:32]	0x0000	0	Black Calibration Error. This flag is set when not enough black samples are available. Black Calibration shall not be valid. Channels 32–47	
		11	139		blackcal_error3	0x0000	0	Black Calibration Status	Status
				[15:0]	blackcal_error[63:48]	0x0000	0	Black Calibration Error. This flag is set when not enough black samples are available. Black Calibration shall not be valid. Channels 48–63	
		12	140		reserved	0x0000	0	Reserved	RW
				[15:0]	reserved	0x0000	0	Reserved	
		13	141		reserved	0xFFFF	65535	Reserved	RW
				[15:0]	reserved	0xFFFF	65535	Reserved	
		16	144		test_configuration	0x0000	0	Data Formating Test Configuration	RW
				[0]	testpattern_en	0x0	0	Insert synthesized test-pattern when '1'	
				[1]	inc_testpattern	0x0	0	Incrementing testpattern when '1', constant test-pattern when '0'	
				[2]	prbs_en	0x0	0	Insert PRBS when '1'	
				[3]	frame_testpattern	0x0	0	Frame test patterns when '1', unframed testpatterns when '0'	
				[4]	reserved	0x0	0	Reserved	
		17	145		reserved	0x0000	0	Reserved	RW
				[15:0]	reserved		0	Reserved	
		18	146		test_configuration0	0x0100	256	Data Formating Test Configuration	RW
				[7:0]	testpattern0_lsb	0x00	0	Testpattern used on datapath #0 when testpattern_en = '1'. Note: Most significant bits are configured in register 150.	

## NOIP1SN025KA, NOIP1SN016KA, NOIP1SN012KA

**Table 23. REGISTER MAP**

Category	Block Offset	Address Offset	Address	Bit Field	Register Name	Default (Hex)	Default	Description	Type
				[15:8]	testpattern1_lsb	0x01	1	Testpattern used on datapath #1 when testpattern_en = '1'. Note: Most significant bits are configured in register 150.	
		19	147		test_configuration1	0x0302	770	Data Formating Test Configuration	RW
				[7:0]	testpattern2_lsb	0x02	2	Testpattern used on datapath #2 when testpattern_en = '1'. Note: Most significant bits are configured in register 150.	
				[15:8]	testpattern3_lsb	0x03	3	Testpattern used on datapath #3 when testpattern_en = '1'. Note: Most significant bits are configured in register 150.	
		20	148		test_configuration2	0x0504	1284	Data Formating Test Configuration	RW
				[7:0]	testpattern4_lsb	0x04	4	Testpattern used on datapath #4 when testpattern_en = '1'. Note: Most significant bits are configured in register 150.	
				[15:8]	testpattern5_lsb	0x05	5	Testpattern used on datapath #5 when testpattern_en = '1'. Note: Most significant bits are configured in register 150.	
		21	149		test_configuration3	0x0706	1798	Data Formating Test Configuration	RW
				[7:0]	testpattern6_lsb	0x06	6	Testpattern used on datapath #6 when testpattern_en = '1'. Note: Most significant bits are configured in register 150.	
				[15:8]	testpattern7_lsb	0x07	7	Testpattern used on datapath #7 when testpattern_en = '1'. Note: Most significant bits are configured in register 150.	
		22	150		test_configuration16	0x0000	0	Data Formating Test Configuration	RW
				[1:0]	testpattern0_msb	0x0	0	Testpattern used when testpattern_en = '1'	
				[3:2]	testpattern1_msb	0x0	0	Testpattern used when testpattern_en = '1'	
				[5:4]	testpattern2_msb	0x0	0	Testpattern used when testpattern_en = '1'	
				[7:6]	testpattern3_msb	0x0	0	Testpattern used when testpattern_en = '1'	
				[9:8]	testpattern4_msb	0x0	0	Testpattern used when testpattern_en = '1'	
				[11:10]	testpattern5_msb	0x0	0	Testpattern used when testpattern_en = '1'	
				[13:12]	testpattern6_msb	0x0	0	Testpattern used when testpattern_en = '1'	
				[15:14]	testpattern7_msb	0x0	0	Testpattern used when testpattern_en = '1'	
		26	154		reserved	0x0000	0	Reserved	RW

**NOIP1SN025KA, NOIP1SN016KA, NOIP1SN012KA**

**Table 23. REGISTER MAP**

Category	Block Offset	Address Offset	Address	Bit Field	Register Name	Default (Hex)	Default	Description	Type
				[15:0]	reserved	0x0000	0	Reserved	
		27	155		reserved	0x0000	0	Reserved	RW
				[15:0]	reserved	0x0000	0	Reserved	
	160				reserved			Reserved	
		0	160		reserved	0x0010	16	Reserved	RW
				[0]	reserved	0x0	0	Reserved	
				[1]	reserved	0x0	0	Reserved	
				[2]	reserved	0x0	0	Reserved	
				[3]	reserved	0x0	0	Reserved	
				[4]	reserved	0x1	1	Reserved	
		1	161		reserved	0x60B8	24760	Reserved	RW
				[9:0]	reserved	0xB8	184	Reserved	
				[15:10]	reserved	0x018	24	Reserved	
		2	162		reserved	0x0080	128	Reserved	RW
				[9:0]	reserved	0x80	128	Reserved	
		3	163		reserved	0x0080	128	Reserved	RW
				[9:0]	reserved	0x80	128	Reserved	
		4	164		reserved	0x0080	128	Reserved	RW
				[9:0]	reserved	0x80	128	Reserved	
		5	165		reserved	0x0080	128	Reserved	RW
				[9:0]	reserved	0x80	128	Reserved	
		6	166		reserved	0x03FF	1023	Reserved	RW
				[15:0]	reserved	0x03FF	1023	Reserved	
		7	167		reserved	0x0800	2048	Reserved	RW
				[1:0]	reserved	0x0	0	Reserved	
				[3:2]	reserved	0x0	0	Reserved	
				[15:4]	reserved	0x080	128	Reserved	
		8	168		reserved	0x0001	1	Reserved	RW
				[15:0]	reserved	0x0001	1	Reserved	
		9	169		reserved	0x0800	2048	Reserved	RW
				[1:0]	reserved	0x0	0	Reserved	
				[3:2]	reserved	0x0	0	Reserved	
				[15:4]	reserved	0x080	128	Reserved	
		10	170		reserved	0x03FF	1023	Reserved	RW
				[15:0]	reserved	0x03FF	1023	Reserved	
		11	171		reserved	0x100D	4109	Reserved	RW
				[1:0]	reserved	0x1	1	Reserved	
				[3:2]	reserved	0x3	3	Reserved	
				[15:4]	reserved	0x100	256	Reserved	
		12	172		reserved	0x0083	131	Reserved	RW
				[7:0]	reserved	0x083	131	Reserved	
				[13:8]	reserved	0x00	0	Reserved	
				[15:14]	reserved	0x0	0	Reserved	
		13	173		reserved	0x2824	10276	Reserved	RW
				[7:0]	reserved	0x024	36	Reserved	
				[15:8]	reserved	0x028	40	Reserved	
		14	174		reserved	0x2A96	10902	Reserved	RW
				[3:0]	reserved	0x6	6	Reserved	



**NOIP1SN025KA, NOIP1SN016KA, NOIP1SN012KA**

**Table 23. REGISTER MAP**

Category	Block Offset	Address Offset	Address	Bit Field	Register Name	Default (Hex)	Default	Description	Type
				[7:4]	reserved	0x9	9	Reserved	
				[11:8]	reserved	0xA	10	Reserved	
				[15:12]	reserved	0x2	2	Reserved	
		15	175		reserved	0x0080	128	Reserved	RW
				[9:0]	reserved	0x080	128	Reserved	
		16	176		reserved	0x0100	256	Reserved	RW
				[9:0]	reserved	0x100	256	Reserved	
		17	177		reserved	0x0100	256	Reserved	RW
				[9:0]	reserved	0x100	256	Reserved	
		18	178		reserved	0x0080	128	Reserved	RW
				[9:0]	reserved	0x080	128	Reserved	
		19	179		reserved	0x00AA	170	Reserved	RW
				[9:0]	reserved	0x0AA	170	Reserved	
		20	180		reserved	0x0100	256	Reserved	RW
				[9:0]	reserved	0x100	256	Reserved	
		21	181		reserved	0x0155	341	Reserved	RW
				[9:0]	reserved	0x155	341	Reserved	
		24	184		reserved	0x0000	0	Reserved	Status
				[15:0]	reserved	0x0000	0	Reserved	
		25	185		reserved	0x0000	0	Reserved	Status
				[7:0]	reserved	0x0	0	Reserved	
		26	186		reserved	0x0000	0	Reserved	Status
				[9:0]	reserved	0x000	0	Reserved	
				[12]	reserved	0x0	0	Reserved	
		27	187		reserved	0x0000	0	Reserved	Status
				[15:0]	reserved	0x0000	0	Reserved	
		28	188		reserved	0x0000	0	Reserved	Status
				[1:0]	reserved	0x0	0	Reserved	
				[3:2]	reserved	0x0	0	Reserved	
				[15:4]	reserved	0x000	0	Reserved	
		29	189		reserved	0x0000	0	Reserved	Status
				[12:0]	reserved	0x000	0	Reserved	
				[13]	reserved	0x0	0	Reserved	
Sequencer	192								
		0	192		general_configuration	0x0000	0	Sequencer General Configuration	RW
				[0]	enable	0x0	0	Enable sequencer '0': Idle, '1': enabled	
				[1]	reserved	0x0	0	Reserved	
				[2]	zero_rot_enable	0x0	0	Zero ROT mode Selection. '0': Normal ROT, '1': Zero ROT	
				[3]	reserved	0x0	0	Reserved	
				[4]	triggered_mode	0x0	0	Triggered Mode Selection '0': Normal Mode, '1': Triggered Mode	
				[5]	slave_mode	0x0	0	Master/Slave Selection '0': master, '1': slave	

**NOIP1SN025KA, NOIP1SN016KA, NOIP1SN012KA**

**Table 23. REGISTER MAP**

Category	Block Offset	Address Offset	Address	Bit Field	Register Name	Default (Hex)	Default	Description	Type
				[6]	nzrot_xsm_delay_enable	0x0	0	Insert delay between end of ROT and start of readout in normal ROT readout mode if '1'. ROT delay is defined by register xsm_delay	
				[7]	subsampling	0x0	0	Subsampling mode selection '0': no subsampling, '1': subsampling	
				[8]	reserved	0x0	0	Reserved	
				[10]	reserved	0x0	0	Reserved	
				[13:11]	monitor_select	0x0	0	Control of the monitor pins	
				[14]	reserved	0x0	0	Reserved	
				[15]	sequence	0x0	0	Enable a sequenced readout with different parameters for even and odd frames.	
		1	193		reserved	0x0000	0	Reserved	RW
				[7:0]	reserved	0x00	0	Reserved	
				[15:8]	reserved	0x00	0	Reserved	
		2	194		integration_control	0x00E4	228	Integration Control	RW
				[0]	reserved	0x0	0	Reserved	
				[1]	reserved	0x0	0	Reserved	
				[2]	fr_mode	0x1	1	Representation of fr_length. '0': reset length '1': frame length	
				[3]	reserved	0x0	0	Reserved	
				[4]	int_priority	0x0	0	Integration Priority '0': Frame readout has priority over integration '1': Integration End has priority over frame readout	
				[5]	halt_mode	0x1	1	The current frame will be completed when the sequencer is disabled and halt_mode = '1'. When '0', the sensor stops immediately when disabled, without finishing the current frame.	
				[6]	fss_enable	0x1	1	Generation of Frame Sequence Start Sync code (FSS) '0': No generation of FSS '1': Generation of FSS	
				[7]	fse_enable	0x1	1	Generation of Frame Sequence End Sync code (FSE) '0': No generation of FSE '1': Generation of FSE	
				[8]	reverse_y	0x0	0	Reverse readout '0': bottom to top readout '1': top to bottom readout	
				[9]	reserved	0x0	0	Reserved	

## NOIP1SN025KA, NOIP1SN016KA, NOIP1SN012KA

**Table 23. REGISTER MAP**

Category	Block Offset	Address Offset	Address	Bit Field	Register Name	Default (Hex)	Default	Description	Type
				[11:10]	subsampling_mode	0x0	0	Subsampling mode 0x0: Subsampling in x and y (VITA compatible) 0x1: Subsampling in x, not y 0x2: Subsampling in y, not x 0x3: Subsampling in x and y	
				[13:12]	reserved	0x0	0	Reserved	
				[14]	reserved	0x0	0	Reserved	
				[15]	reserved	0x0	0	Reserved	
		3	195		roi_active0_0	0x0001	1	Active ROI Selection	RW
				[15:0]	roi_active0	0x01	1	Active ROI Selection [0] Roi0 Active [1] Roi1 Active ... [15] Roi15 Active	
		4	196		roi_active1_0	0x0000	0	Active ROI Selection	RW
				[15:0]	roi_active1_0	0x0000	0	Active ROI Selection [0] Roi16 Active [1] Roi17 Active ... [15] Roi31 Active	
		5	197		black_lines	0x0102	258	Black Line Configuration	RW
				[7:0]	black_lines	0x02	2	Number of black lines. Minimum is 1. Range 1–255	
				[12:8]	gate_first_line	0x1	1	Blank out first lines 0: no blank 1–31: blank 1–31 lines	
		6	198		reserved	0x0000	0	Reserved	RW
				[11:0]	reserved	0x000	0	Reserved	
		7	199		mult_timer0	0x0001	1	Exposure/Frame Rate Configuration	RW
				[15:0]	mult_timer0	0x0001	1	Mult Timer Defines granularity (unit = 1/PLL clock) of exposure and reset_length	
		8	200		fr_length0	0x0000	0	Exposure/Frame Rate Configuration	RW
				[15:0]	fr_length0	0x0000	0	Frame/Reset length Reset length when fr_mode = '0', Frame Length when fr_mode = '1' Granularity defined by mult_timer	
		9	201		exposure0	0x0000	0	Exposure/Frame Rate Configuration	RW
				[15:0]	exposure0	0x0000	0	Exposure Time Granularity defined by mult_timer	
		10	202		reserved	0x0000	0	Reserved	RW
				[15:0]	reserved	0x0000	0	Reserved	
		11	203		reserved	0x0000	0	Reserved	RW
				[15:0]	reserved	0x0000	0	Reserved	
		12	204		gain_configuration0	0x01E3	483	Gain Configuration	RW
				[4:0]	mux_gainsw0	0x03	3	Column Gain Setting	
				[12:5]	reserved	0xF	15	Reserved	

**NOIP1SN025KA, NOIP1SN016KA, NOIP1SN012KA**

**Table 23. REGISTER MAP**

Category	Block Offset	Address Offset	Address	Bit Field	Register Name	Default (Hex)	Default	Description	Type
				[13]	gain_lat_comp	0x0	0	Postpone gain update by 1 frame when '1' to compensate for exposure time updates latency. Gain is applied at start of next frame if '0'	
		13	205		digital_gain_configuration0	0x0080	128	Gain Configuration	RW
				[11:0]	db_gain0	0x080	128	Digital Gain	
		14	206		sync_configuration	0x037F	895	Synchronization Configuration	RW
				[0]	sync_rs_x_length	0x1	1	Update of rs_x_length will not be sync'ed at start of frame when '0'	
				[1]	sync_black_lines	0x1	1	Update of black_lines will not be sync'ed at start of frame when '0'	
				[2]	sync_dummy_lines	0x1	1	Update of dummy_lines will not be sync'ed at start of frame when '0'	
				[3]	sync_exposure	0x1	1	Update of exposure will not be sync'ed at start of frame when '0'	
				[4]	sync_gain	0x1	1	Update of gain settings (gain_sw, afe_gain) will not be sync'ed at start of frame when '0'	
				[5]	sync_roi	0x1	1	Update of roi updates (active_roi) will not be sync'ed at start of frame when '0'	
				[6]	sync_ref_lines	0x1	1	Update of ref_lines will not be sync'ed at start of frame when '0'	
				[8]	blank_roi_switch	0x1	1	Blank first frame after ROI switching	
				[9]	blank_subsampling_ss	0x1	1	Blank first frame after subsampling mode switching '0': No blanking '1': Blanking	
				[10]	exposure_sync_mode	0x0	0	When '0', exposure configurations are sync'ed at the start of FOT. When '1', exposure configurations sync is disabled (continuously syncing). This mode is only relevant for Triggered – master mode, where the exposure configurations are sync'ed at the start of exposure rather than the start of FOT. For all other modes it should be set to '0'. Note: Sync is still postponed if sync_exposure='0'.	
		15	207		ref_lines	0x0000	0	Reference Line Configuration	RW
				[7:0]	ref_lines	0x00	0	Number of Reference Lines 0–255	
		16	208		reserved	0x4F00	20224	Reserved	RW
				[7:0]	reserved	0x00	0	Reserved	
				[15:8]	reserved	0x4F	79	Reserved	

**NOIP1SN025KA, NOIP1SN016KA, NOIP1SN012KA**

**Table 23. REGISTER MAP**

Category	Block Offset	Address Offset	Address	Bit Field	Register Name	Default (Hex)	Default	Description	Type
		19	211		reserved	0x0E5B	3675	Reserved	RW
				[0]	reserved	0x1	1	Reserved	
				[1]	reserved	0x1	1	Reserved	
				[2]	reserved	0x0	0	Reserved	
				[3]	reserved	0x1	1	Reserved	
				[6:4]	reserved	0x5	5	Reserved	
				[15:8]	reserved	0xE	14	Reserved	
		20	212		reserved	0x0000	0	Reserved	RW
				[12:0]	reserved	0x0000	0	Reserved	
				[15]	reserved	0x0	0	Reserved	
		21	213		reserved	0x13FF	5119	Reserved	RW
				[12:0]	reserved	0x13FF	5119	Reserved	
		22	214		reserved	0x0000	0	Reserved	RW
				[7:0]	reserved	0x00	0	Reserved	
				[15:8]	reserved	0x0	0	Reserved	
		23	215		reserved	0x0103	259	Reserved	RW
				[0]	reserved	0x1	1	Reserved	
				[1]	reserved	0x1	1	Reserved	
				[2]	reserved	0x0	0	Reserved	
				[3]	reserved	0x0	0	Reserved	
				[4]	reserved	0x0	0	Reserved	
				[5]	reserved	0x0	0	Reserved	
				[6]	reserved	0x0	0	Reserved	
				[7]	reserved	0x0	0	Reserved	
				[8]	reserved	0x1	1	Reserved	
				[9]	reserved	0x0	0	Reserved	
				[10]	reserved	0x0	0	Reserved	
				[11]	reserved	0x0	0	Reserved	
				[12]	reserved	0x0	0	Reserved	
				[13]	reserved	0x0	0	Reserved	
				[14]	reserved	0x0	0	Reserved	
		24	216		reserved	0x7F08	32520	Reserved	RW
				[6:0]	reserved	0x08	8	Reserved	
				[14:8]	reserved	0x7F	127	Reserved	
		25	217		reserved	0x4444	17476	Reserved	RW
				[6:0]	reserved	0x44	68	Reserved	
				[14:8]	reserved	0x44	68	Reserved	
		26	218		reserved	0x4444	17476	Reserved	RW
				[6:0]	reserved	0x44	68	Reserved	
				[14:8]	reserved	0x44	68	Reserved	
		27	219		reserved	0x0016	22	Reserved	RW
				[6:0]	reserved	0x016	22	Reserved	
				[14:8]	reserved	0x00	0	Reserved	
		28	220		reserved	0x301F	12319	Reserved	RW
				[6:0]	reserved	0x1F	31	Reserved	
				[14:8]	reserved	0x30	48	Reserved	
		29	221		reserved	0x6245	25157	Reserved	RW
				[6:0]	reserved	0x45	69	Reserved	

**NOIP1SN025KA, NOIP1SN016KA, NOIP1SN012KA**

**Table 23. REGISTER MAP**

Category	Block Offset	Address Offset	Address	Bit Field	Register Name	Default (Hex)	Default	Description	Type
				[14:8]	reserved	0x62	98	Reserved	
		30	222		reserved	0x6230	25136	Reserved	RW
				[6:0]	reserved	0x30	48	Reserved	
				[14:8]	reserved	0x62	98	Reserved	
		31	223		reserved	0x001A	26	Reserved	RW
				[6:0]	reserved	0x1A	26	Reserved	
		32	224		reserved	0x3E01	15873	Reserved	RW
				[3:0]	reserved	0x1	1	Reserved	
				[7:4]	reserved	0x00	0	Reserved	
				[8]	reserved	0x0	0	Reserved	
				[9]	reserved	0x1	1	Reserved	
				[10]	reserved	0x1	1	Reserved	
				[11]	reserved	0x1	1	Reserved	
				[12]	reserved	0x1	1	Reserved	
				[13]	reserved	0x1	1	Reserved	
		33	225		reserved	0x5EF1	24305	Reserved	RW
				[4:0]	reserved	0x11	17	Reserved	
				[9:5]	reserved	0x17	23	Reserved	
				[14:10]	reserved	0x17	23	Reserved	
				[15]	reserved	0x0	0	Reserved	
		34	226		reserved	0x6000	24576	Reserved	RW
				[4:0]	reserved	0x00	0	Reserved	
				[9:5]	reserved	0x00	0	Reserved	
				[14:10]	reserved	0x18	24	Reserved	
				[15]	reserved	0x0	0	Reserved	
		35	227		reserved	0x0000	0	Reserved	RW
				[0]	reserved	0x0	0	Reserved	
				[1]	reserved	0x0	0	Reserved	
				[2]	reserved	0x0	0	Reserved	
				[3]	reserved	0x0	0	Reserved	
				[4]	reserved	0x0	0	Reserved	
		36	228		roi_active0_1	0x0001	1	Active ROI Selection	RW
				[7:0]	roi_active1	0x01	1	Active ROI Selection [0] Roi0 Active [1] Roi1 Active ... [15] Roi15 Active	
		37	229		roi_active1_1	0x0000	0	Active ROI Selection	RW
				[15:0]	roi_active1_1	0x0000	0	Active ROI Selection [0] Roi16 Active [1] Roi17 Active ... [15] Roi31 Active	
		38	230		mult_timer1	0x0001	1	Exposure/Frame Rate Configuration	RW
				[15:0]	mult_timer1	0x0001	1	Mult Timer Defines granularity (unit = 1/PLL clock) of exposure and reset_length	
		39	231		fr_length1	0x0000	0	Exposure/Frame Rate Configuration	RW

# NOIP1SN025KA, NOIP1SN016KA, NOIP1SN012KA

**Table 23. REGISTER MAP**

Category	Block Offset	Address Offset	Address	Bit Field	Register Name	Default (Hex)	Default	Description	Type
				[15:0]	fr_length1	0x0000	0	Frame/Reset length Reset length when fr_mode = '0', Frame Length when fr_mode = '1' Granularity defined by mult_timer	
		40	232		exposure1	0x0000	0	Exposure/Frame Rate Configuration	RW
				[15:0]	exposure1	0x0000	0	Exposure Time Granularity defined by mult_timer	
		41	233		reserved	0x0000	0	Reserved	RW
				[15:0]	reserved	0x0000	0	Reserved	
		42	234		reserved	0x0000	0	Reserved	RW
				[15:0]	reserved	0x0000	0	Reserved	
		43	235		gain_configuration1	0x01E3	483	Gain Configuration	RW
				[4:0]	mux_gainsw1	0x03	3	Column Gain Setting	
				[12:5]	afe_gain1	0xF	15	AFE Programmable Gain Setting	
		44	236		digital_gain_configuration1	0x0080	128	Gain Configuration	RW
				[11:0]	db_gain1	0x080	128	Digital Gain	
		45	237		reserved	0x0000	0	Reserved	RW
				[15:0]	reserved	0x0000	0	Reserved	
		46	238		reserved	0xFFFF	65535	Reserved	RW
				[15:0]	reserved	0xFFFF	65535	Reserved	
		47	239		reserved	0x0000	0	Reserved	RW
				[15:0]	reserved	0x0	0	Reserved	
		48	240		x_resolution	0x0050 [0x0042, 0x0042, 0x003E]	80 [66, 66, 62]	Sequencer Status	Status
				[7:0]	x_resolution	0x0050 [0x0042, 0x0042, 0x003E]	80 [66, 66, 62]	Sensor x Resolution	
		49	241		y_resolution	0x1400	5120	Sequencer Status	Status
				[12:0]	y_resolution	0x1400 [0x1010, 0x0C10, 0x0B60]	5120 [4112, 3088, 2912]	Sequencer Status	
		50	242		mult_timer_status	0x0000	0	Sequencer Status	Status
				[15:0]	mult_timer	0x0000	0	Mult Timer Status (Master Global Shutter only)	
		51	243		reset_length_status	0x0000	0	Sequencer Status	Status
				[15:0]	reset_length	0x0000	0	Current Reset Length (not in Slave mode)	
		52	244		exposure_status	0x0000	0	Sequencer Status	Status
				[15:0]	exposure	0x0000	0	Current Exposure Time (not in Slave mode)	
		53	245		exposure_ds_status	0x0000	0	Sequencer Status	Status
				[15:0]	exposure_ds	0x0000	0	Current Exposure Time (not in Slave mode)	
		54	246		exposure_ts_status	0x0000	0	Sequencer Status	Status
				[15:0]	exposure_ts	0x0000	0	Current Exposure Time (not in Slave mode)	
		55	247		gain_status	0x0000	0	Sequencer Status	Status

# NOIP1SN025KA, NOIP1SN016KA, NOIP1SN012KA

**Table 23. REGISTER MAP**

Category	Block Offset	Address Offset	Address	Bit Field	Register Name	Default (Hex)	Default	Description	Type
				[4:0]	mux_gainsw	0x00	0	Current Column Gain Setting	
				[12:5]	afe_gain	0x00	0	Current AFE Programmable Gain	
		56	248		digital_gain_status	0x0000	0	Sequencer Status	Status
				[11:0]	db_gain	0x000	0	Digital Gain	
				[12]	reserved	0x0	0	Reserved	
				[13]	reserved	0x0	0	Reserved	
		58	250		reserved	0x0423	1059	Reserved	RW
				[4:0]	reserved	0x03	3	Reserved	
				[9:5]	reserved	0x01	1	Reserved	
				[14:10]	reserved	0x01	1	Reserved	
		59	251		reserved	0x030F	783	Reserved	RW
				[7:0]	reserved	0xF	15	Reserved	
				[15:8]	reserved	0x3	3	Reserved	
		60	252		reserved	0x0601	1537	Reserved	RW
				[7:0]	reserved	0x1	1	Reserved	
				[15:8]	reserved	0x6	6	Reserved	
		61	253		reserved	0x0000	0	Reserved	RW
				[7:0]	reserved	0x00	0	Reserved	
				[15:8]	reserved	0x00	0	Reserved	
		62	254		reserved	0x0000	0	Reserved	RW
				[12:0]	reserved	0x0000	0	Reserved	
		63	255		reserved	0x0000	0	Reserved	RW
				[12:0]	reserved	0x0000	0	Reserved	
Sequencer ROI	256								
		0	256		roi0_configuration0	0x4F00	20224	ROI Configuration	RW
				[7:0]	x_start	0x00	0	X Start Configuration	
				[15:8]	x_end	0x4F	79	X End Configuration	
		1	257		roi0_configuration1	0x0000	0	ROI Configuration	RW
				[12:0]	y_start	0x0000	0	Y Start Configuration	
		2	258		roi0_configuration2	0x13FF	5119	ROI Configuration	RW
				[12:0]	y_end	0x13FF	5119	Y End Configuration	
		3	259		roi1_configuration0	0x4F00	20224	ROI Configuration	RW
				[7:0]	x_start	0x00	0	X Start Configuration	
				[15:8]	x_end	0x4F	79	X End Configuration	
		4	260		roi1_configuration1	0x0000	0	ROI Configuration	RW
				[12:0]	y_start	0x0000	0	Y Start Configuration	
		5	261		roi1_configuration2	0x13FF	5119	ROI Configuration	RW
				[12:0]	y_end	0x13FF	5119	Y End Configuration	
		6	262		roi2_configuration0	0x4F00	20224	ROI Configuration	RW
				[7:0]	x_start	0x00	0	X Start Configuration	
				[15:8]	x_end	0x4F	79	X End Configuration	
		7	263		roi2_configuration1	0x0000	0	ROI Configuration	RW
				[12:0]	y_start	0x0000	0	Y Start Configuration	
		8	264		roi2_configuration2	0x13FF	5119	ROI Configuration	RW
				[12:0]	y_end	0x13FF	5119	Y End Configuration	
		9	265		roi3_configuration0	0x4F00	20224	ROI Configuration	RW



# NOIP1SN025KA, NOIP1SN016KA, NOIP1SN012KA

**Table 23. REGISTER MAP**

Category	Block Offset	Address Offset	Address	Bit Field	Register Name	Default (Hex)	Default	Description	Type
				[7:0]	x_start	0x00	0	X Start Configuration	
				[15:8]	x_end	0x4F	79	X End Configuration	
		10	266		roi3_configuration1	0x0000	0	ROI Configuration	RW
				[12:0]	y_start	0x0000	0	Y Start Configuration	
		11	267		roi3_configuration2	0x13FF	5119	ROI Configuration	RW
				[12:0]	y_end	0x13FF	5119	Y End Configuration	
		12	268		roi4_configuration0	0x4F00	20224	ROI Configuration	RW
				[7:0]	x_start	0x00	0	X Start Configuration	
				[15:8]	x_end	0x4F	79	X End Configuration	
		13	269		roi4_configuration1	0x0000	0	ROI Configuration	RW
				[12:0]	y_start	0x0000	0	Y Start Configuration	
		14	270		roi4_configuration2	0x13FF	5119	ROI Configuration	RW
				[12:0]	y_end	0x13FF	5119	Y End Configuration	
		15	271		roi5_configuration0	0x4F00	20224	ROI Configuration	RW
				[7:0]	x_start	0x00	0	X Start Configuration	
				[15:8]	x_end	0x4F	79	X End Configuration	
		16	272		roi5_configuration1	0x0000	0	ROI Configuration	RW
				[12:0]	y_start	0x0000	0	Y Start Configuration	
		17	273		roi5_configuration2	0x13FF	5119	ROI Configuration	RW
				[12:0]	y_end	0x13FF	5119	Y End Configuration	
		18	274		roi6_configuration0	0x4F00	20224	ROI Configuration	RW
				[7:0]	x_start	0x00	0	X Start Configuration	
				[15:8]	x_end	0x4F	79	X End Configuration	
		19	275		roi6_configuration1	0x0000	0	ROI Configuration	RW
				[12:0]	y_start	0x0000	0	Y Start Configuration	
		20	276		roi6_configuration2	0x13FF	5119	ROI Configuration	RW
				[12:0]	y_end	0x13FF	5119	Y End Configuration	
		21	277		roi7_configuration0	0x4F00	20224	ROI Configuration	RW
				[7:0]	x_start	0x00	0	X Start Configuration	
				[15:8]	x_end	0x4F	79	X End Configuration	
		22	278		roi7_configuration1	0x0000	0	ROI Configuration	RW
				[12:0]	y_start	0x0000	0	Y Start Configuration	
		23	279		roi7_configuration2	0x13FF	5119	ROI Configuration	RW
				[12:0]	y_end	0x13FF	5119	Y End Configuration	
		24	280		roi8_configuration0	0x4F00	20224	ROI Configuration	RW
				[7:0]	x_start	0x00	0	X Start Configuration	
				[15:8]	x_end	0x4F	79	X End Configuration	
		25	281		roi8_configuration1	0x0000	0	ROI Configuration	RW
				[12:0]	y_start	0x0000	0	Y Start Configuration	
		26	282		roi8_configuration2	0x13FF	5119	ROI Configuration	RW
				[12:0]	y_end	0x13FF	5119	Y End Configuration	
		27	283		roi9_configuration0	0x4F00	20224	ROI Configuration	RW
				[7:0]	x_start	0x00	0	X Start Configuration	
				[15:8]	x_end	0x4F	79	X End Configuration	
		28	284		roi9_configuration1	0x0000	0	ROI Configuration	RW
				[12:0]	y_start	0x0000	0	Y Start Configuration	
		29	285		roi9_configuration2	0x13FF	5119	ROI Configuration	RW
				[12:0]	y_end	0x13FF	5119	Y End Configuration	

# NOIP1SN025KA, NOIP1SN016KA, NOIP1SN012KA

**Table 23. REGISTER MAP**

Category	Block Offset	Address Offset	Address	Bit Field	Register Name	Default (Hex)	Default	Description	Type
		30	286		roi10_configuration0	0x4F00	20224	ROI Configuration	RW
				[7:0]	x_start	0x00	0	X Start Configuration	
				[15:8]	x_end	0x4F	79	X End Configuration	
		31	287		roi10_configuration1	0x0000	0	ROI Configuration	RW
				[12:0]	y_start	0x0000	0	Y Start Configuration	
		32	288		roi10_configuration2	0x13FF	5119	ROI Configuration	RW
				[12:0]	y_end	0x13FF	5119	Y End Configuration	
		33	289		roi11_configuration0	0x4F00	20224	ROI Configuration	RW
				[7:0]	x_start	0x00	0	X Start Configuration	
				[15:8]	x_end	0x4F	79	X End Configuration	
		34	290		roi11_configuration1	0x0000	0	ROI Configuration	RW
				[12:0]	y_start	0x0000	0	Y Start Configuration	
		35	291		roi11_configuration2	0x13FF	5119	ROI Configuration	RW
				[12:0]	y_end	0x13FF	5119	Y End Configuration	
		36	292		roi12_configuration0	0x4F00	20224	ROI Configuration	RW
				[7:0]	x_start	0x00	0	X Start Configuration	
				[15:8]	x_end	0x4F	79	X End Configuration	
		37	293		roi12_configuration1	0x0000	0	ROI Configuration	RW
				[12:0]	y_start	0x0000	0	Y Start Configuration	
		38	294		roi12_configuration2	0x13FF	5119	ROI Configuration	RW
				[12:0]	y_end	0x13FF	5119	Y End Configuration	
		39	295		roi13_configuration0	0x4F00	20224	ROI Configuration	RW
				[7:0]	x_start	0x00	0	X Start Configuration	
				[15:8]	x_end	0x4F	79	X End Configuration	
		40	296		roi13_configuration1	0x0000	0	ROI Configuration	RW
				[12:0]	y_start	0x0000	0	Y Start Configuration	
		41	297		roi13_configuration2	0x13FF	5119	ROI Configuration	RW
				[12:0]	y_end	0x13FF	5119	Y End Configuration	
		42	298		roi14_configuration0	0x4F00	20224	ROI Configuration	RW
				[7:0]	x_start	0x00	0	X Start Configuration	
				[15:8]	x_end	0x4F	79	X End Configuration	
		43	299		roi14_configuration1	0x0000	0	ROI Configuration	RW
				[12:0]	y_start	0x0000	0	Y Start Configuration	
		44	300		roi14_configuration2	0x13FF	5119	ROI Configuration	RW
				[12:0]	y_end	0x13FF	5119	Y End Configuration	
		45	301		roi15_configuration0	0x4F00	20224	ROI Configuration	RW
				[7:0]	x_start	0x00	0	X Start Configuration	
				[15:8]	x_end	0x4F	79	X End Configuration	
		46	302		roi15_configuration1	0x0000	0	ROI Configuration	RW
				[12:0]	y_start	0x0000	0	Y Start Configuration	
		47	303		roi15_configuration2	0x13FF	5119	ROI Configuration	RW
				[12:0]	y_end	0x13FF	5119	Y End Configuration	
		48	304		roi16_configuration0	0x4F00	20224	ROI Configuration	RW
				[7:0]	x_start	0x00	0	X Start Configuration	
				[15:8]	x_end	0x4F	79	X End Configuration	
		49	305		roi16_configuration1	0x0000	0	ROI Configuration	RW
				[12:0]	y_start	0x0000	0	Y Start Configuration	
		50	306		roi16_configuration2	0x13FF	5119	ROI Configuration	RW

# NOIP1SN025KA, NOIP1SN016KA, NOIP1SN012KA

**Table 23. REGISTER MAP**

Category	Block Offset	Address Offset	Address	Bit Field	Register Name	Default (Hex)	Default	Description	Type
				[12:0]	y_end	0x13FF	5119	Y End Configuration	
		51	307		roi17_configuration0	0x4F00	20224	ROI Configuration	RW
				[7:0]	x_start	0x00	0	X Start Configuration	
				[15:8]	x_end	0x4F	79	X End Configuration	
		52	308		roi17_configuration1	0x0000	0	ROI Configuration	RW
				[12:0]	y_start	0x0000	0	Y Start Configuration	
		53	309		roi17_configuration2	0x13FF	5119	ROI Configuration	RW
				[12:0]	y_end	0x13FF	5119	Y End Configuration	
		54	310		roi18_configuration0	0x4F00	20224	ROI Configuration	RW
				[7:0]	x_start	0x00	0	X Start Configuration	
				[15:8]	x_end	0x4F	79	X End Configuration	
		55	311		roi18_configuration1	0x0000	0	ROI Configuration	RW
				[12:0]	y_start	0x0000	0	Y Start Configuration	
		56	312		roi18_configuration2	0x13FF	5119	ROI Configuration	RW
				[12:0]	y_end	0x13FF	5119	Y End Configuration	
		57	313		roi19_configuration0	0x4F00	20224	ROI Configuration	RW
				[7:0]	x_start	0x00	0	X Start Configuration	
				[15:8]	x_end	0x4F	79	X End Configuration	
		58	314		roi19_configuration1	0x0000	0	ROI Configuration	RW
				[12:0]	y_start	0x0000	0	Y Start Configuration	
		59	315		roi19_configuration2	0x13FF	5119	ROI Configuration	RW
				[12:0]	y_end	0x13FF	5119	Y End Configuration	
		60	316		roi20_configuration0	0x4F00	20224	ROI Configuration	RW
				[7:0]	x_start	0x00	0	X Start Configuration	
				[15:8]	x_end	0x4F	79	X End Configuration	
		61	317		roi20_configuration1	0x0000	0	ROI Configuration	RW
				[12:0]	y_start	0x0000	0	Y Start Configuration	
		62	318		roi20_configuration2	0x13FF	5119	ROI Configuration	RW
				[12:0]	y_end	0x13FF	5119	Y End Configuration	
		63	319		roi21_configuration0	0x4F00	20224	ROI Configuration	RW
				[7:0]	x_start	0x00	0	X Start Configuration	
				[15:8]	x_end	0x4F	79	X End Configuration	
		64	320		roi21_configuration1	0x0000	0	ROI Configuration	RW
				[12:0]	y_start	0x0000	0	Y Start Configuration	
		65	321		roi21_configuration2	0x13FF	5119	ROI Configuration	RW
				[12:0]	y_end	0x13FF	5119	Y End Configuration	
		66	322		roi22_configuration0	0x4F00	20224	ROI Configuration	RW
				[7:0]	x_start	0x00	0	X Start Configuration	
				[15:8]	x_end	0x4F	79	X End Configuration	
		67	323		roi22_configuration1	0x0000	0	ROI Configuration	RW
				[12:0]	y_start	0x0000	0	Y Start Configuration	
		68	324		roi22_configuration2	0x13FF	5119	ROI Configuration	RW
				[12:0]	y_end	0x13FF	5119	Y End Configuration	
		69	325		roi23_configuration0	0x4F00	20224	ROI Configuration	RW
				[7:0]	x_start	0x00	0	X Start Configuration	
				[15:8]	x_end	0x4F	79	X End Configuration	
		70	326		roi23_configuration1	0x0000	0	ROI Configuration	RW
				[12:0]	y_start	0x0000	0	Y Start Configuration	

## NOIP1SN025KA, NOIP1SN016KA, NOIP1SN012KA

**Table 23. REGISTER MAP**

Category	Block Offset	Address Offset	Address	Bit Field	Register Name	Default (Hex)	Default	Description	Type
		71	327		roi23_configuration2	0x13FF	5119	ROI Configuration	RW
				[12:0]	y_end	0x13FF	5119	Y End Configuration	
		72	328		roi24_configuration0	0x4F00	20224	ROI Configuration	RW
				[7:0]	x_start	0x00	0	X Start Configuration	
				[15:8]	x_end	0x4F	79	X End Configuration	
		73	329		roi24_configuration1	0x0000	0	ROI Configuration	RW
				[12:0]	y_start	0x0000	0	Y Start Configuration	
		74	330		roi24_configuration2	0x13FF	5119	ROI Configuration	RW
				[12:0]	y_end	0x13FF	5119	Y End Configuration	
		75	331		roi25_configuration0	0x4F00	20224	ROI Configuration	RW
				[7:0]	x_start	0x00	0	X Start Configuration	
				[15:8]	x_end	0x4F	79	X End Configuration	
		76	332		roi25_configuration1	0x0000	0	ROI Configuration	RW
				[12:0]	y_start	0x0000	0	Y Start Configuration	
		77	333		roi25_configuration2	0x13FF	5119	ROI Configuration	RW
				[12:0]	y_end	0x13FF	5119	Y End Configuration	
		78	334		roi26_configuration0	0x4F00	20224	ROI Configuration	RW
				[7:0]	x_start	0x00	0	X Start Configuration	
				[15:8]	x_end	0x4F	79	X End Configuration	
		79	335		roi26_configuration1	0x0000	0	ROI Configuration	RW
				[12:0]	y_start	0x0000	0	Y Start Configuration	
		80	336		roi26_configuration2	0x13FF	5119	ROI Configuration	RW
				[12:0]	y_end	0x13FF	5119	Y End Configuration	
		81	337		roi27_configuration0	0x4F00	20224	ROI Configuration	RW
				[7:0]	x_start	0x00	0	X Start Configuration	
				[15:8]	x_end	0x4F	79	X End Configuration	
		82	338		roi27_configuration1	0x0000	0	ROI Configuration	RW
				[12:0]	y_start	0x0000	0	Y Start Configuration	
		83	339		roi27_configuration2	0x13FF	5119	ROI Configuration	RW
				[12:0]	y_end	0x13FF	5119	Y End Configuration	
		84	340		roi28_configuration0	0x4F00	20224	ROI Configuration	RW
				[7:0]	x_start	0x00	0	X Start Configuration	
				[15:8]	x_end	0x4F	79	X End Configuration	
		85	341		roi28_configuration1	0x0000	0	ROI Configuration	RW
				[12:0]	y_start	0x0000	0	Y Start Configuration	
		86	342		roi28_configuration2	0x13FF	5119	ROI Configuration	RW
				[12:0]	y_end	0x13FF	5119	Y End Configuration	
		87	343		roi29_configuration0	0x4F00	20224	ROI Configuration	RW
				[7:0]	x_start	0x00	0	X Start Configuration	
				[15:8]	x_end	0x4F	79	X End Configuration	
		88	344		roi29_configuration1	0x0000	0	ROI Configuration	RW
				[12:0]	y_start	0x0000	0	Y Start Configuration	
		89	345		roi29_configuration2	0x13FF	5119	ROI Configuration	RW
				[12:0]	y_end	0x13FF	5119	Y End Configuration	
		90	346		roi30_configuration0	0x4F00	20224	ROI Configuration	RW
				[7:0]	x_start	0x00	0	X Start Configuration	
				[15:8]	x_end	0x4F	79	X End Configuration	
		91	347		roi30_configuration1	0x0000	0	ROI Configuration	RW

**NOIP1SN025KA, NOIP1SN016KA, NOIP1SN012KA**

**Table 23. REGISTER MAP**

Category	Block Offset	Address Offset	Address	Bit Field	Register Name	Default (Hex)	Default	Description	Type
				[12:0]	y_start	0x0000	0	Y Start Configuration	
		92	348		roi30_configuration2	0x13FF	5119	ROI Configuration	RW
				[12:0]	y_end	0x13FF	5119	Y End Configuration	
		93	349		roi31_configuration0	0x4F00	20224	ROI Configuration	RW
				[7:0]	x_start	0x00	0	X Start Configuration	
				[15:8]	x_end	0x4F	79	X End Configuration	
		94	350		roi31_configuration1	0x0000	0	ROI Configuration	RW
				[12:0]	y_start	0x0000	0	Y Start Configuration	
		95	351		roi31_configuration2	0x13FF	5119	ROI Configuration	RW
				[12:0]	y_end	0x13FF	5119	Y End Configuration	
	384								
		0	384		reserved			Reserved	RW
				[15:0]	reserved			Reserved	
			...	...	...			...	
					...			...	
		127	511					Reserved	
				[15:0]	reserved			Reserved	

# NOIP1SN025KA, NOIP1SN016KA, NOIP1SN012KA

## PACKAGE INFORMATION

### Pin Description

Refer to Electrical Specifications on page 4 for power supplies and references. The CMOS IO follow the JEDEC Standard (JEDEC–JESD8C–01).

**Table 24. PIN DESCRIPTION**

Pin No.	Name	Type	Direction	Description
A01	vddd_18	Supply		Digital supply - 1.8 V domain
A02	mbs2_out	Analog	Out	For test purposes only. Do not connect
A03	adc_dout1	CMOS	Out	For test purposes only. Do not connect
A04	gnd_colbias	Ground		Column biasing ground - Connect to ground
A05	gnd_colbias	Ground		Column biasing ground - Connect to ground
A06	vdda_33	Supply		Analog supply - 3.3 V domain
A07	vdda_33	Supply		Analog supply - 3.3 V domain
A08	vdda_33	Supply		Analog supply - 3.3 V domain
A09	vdda_33	Supply		Analog supply - 3.3 V domain
A10	vdda_33	Supply		Analog supply - 3.3 V domain
A11	vdda_33	Supply		Analog supply - 3.3 V domain
A12	vdda_33	Supply		Analog supply - 3.3 V domain
A13	vdda_33	Supply		Analog supply - 3.3 V domain
A14	vdda_33	Supply		Analog supply - 3.3 V domain
A15	vdda_33	Supply		Analog supply - 3.3 V domain
A16	vdda_33	Supply		Analog supply - 3.3 V domain
A17	vdda_33	Supply		Analog supply - 3.3 V domain
A18	vdda_33	Supply		Analog supply - 3.3 V domain
A19	vdda_33	Supply		Analog supply - 3.3 V domain
A20	vdda_33	Supply		Analog supply - 3.3 V domain
A21	vdda_33	Supply		Analog supply - 3.3 V domain
A22	vdda_33	Supply		Analog supply - 3.3 V domain
A23	vdda_33	Supply		Analog supply - 3.3 V domain
A24	vddd_18	Supply		Digital supply - 1.8 V domain
A25	vddd_18	Supply		Digital supply - 1.8 V domain
B01	vddd_33	Supply		Digital supply - 3.3 V domain
B02	ibias_master	Analog	In/Out	Bias reference - Connect with 47 k $\Omega$ to ibias_out
B03	adc_dout2	CMOS	Out	For test purposes only. Do not connect
B04	gnd_colbias	Ground		Column biasing ground - Connect to ground
B05	doutn30	LVDS	Out	LVDS data out negative - Channel 30
B06	doutp28	LVDS	Out	LVDS data out positive - Channel 28
B07	doutn27	LVDS	Out	LVDS data out negative - Channel 27
B08	doutn25	LVDS	Out	LVDS data out negative - Channel 25
B09	doutn23	LVDS	Out	LVDS data out negative - Channel 23
B10	doutn21	LVDS	Out	LVDS data out negative - Channel 21
B11	doutn19	LVDS	Out	LVDS data out negative - Channel 19
B12	doutp17	LVDS	Out	LVDS data out positive - Channel 17
B13	doutn16	LVDS	Out	LVDS data out negative - Channel 16

## NOIP1SN025KA, NOIP1SN016KA, NOIP1SN012KA

**Table 24. PIN DESCRIPTION**

Pin No.	Name	Type	Direction	Description
B14	doutn14	LVDS	Out	LVDS data out negative - Channel 14
B15	doutp12	LVDS	Out	LVDS data out positive - Channel 12
B16	doutp10	LVDS	Out	LVDS data out positive - Channel 10
B17	doutp8	LVDS	Out	LVDS data out positive - Channel 8
B18	doutp6	LVDS	Out	LVDS data out positive - Channel 6
B19	doutp4	LVDS	Out	LVDS data out positive - Channel 4
B20	doutn3	LVDS	Out	LVDS data out negative - Channel 3
B21	doutp1	LVDS	Out	LVDS data out positive - Channel 1
B22	gnd_colbias	Ground		Column biasing ground - Connect to ground
B23	clock_inp	LVDS	In	LVDS clock in positive
B24	clock_inn	LVDS	In	LVDS clock in negative
B25	vddd_33	Supply		Digital supply - 3.3 V domain
C01	vddd_33	Supply		Digital supply - 3.3 V domain
C02	ibias_out	Analog	In/Out	Bias ground reference - Connect with 47 kΩ to ibias_master
C03	adc_dout9	CMOS	Out	For test purposes only. Do not connect
C04	gnd_colbias	Ground		Column biasing ground - Connect to ground
C05	doutp30	LVDS	Out	LVDS data out positive - Channel 30
C06	doutn28	LVDS	Out	LVDS data out negative - Channel 28
C07	doutp27	LVDS	Out	LVDS data out positive - Channel 27
C08	doutp25	LVDS	Out	LVDS data out positive - Channel 25
C09	doutp23	LVDS	Out	LVDS data out positive - Channel 23
C10	doutp21	LVDS	Out	LVDS data out positive - Channel 21
C11	doutp19	LVDS	Out	LVDS data out positive - Channel 19
C12	doutn17	LVDS	Out	LVDS data out negative - Channel 17
C13	doutp16	LVDS	Out	LVDS data out positive - Channel 16
C14	doutp14	LVDS	Out	LVDS data out positive - Channel 14
C15	doutn12	LVDS	Out	LVDS data out negative - Channel 12
C16	doutn10	LVDS	Out	LVDS data out negative - Channel 10
C17	doutn8	LVDS	Out	LVDS data out negative - Channel 8
C18	doutn6	LVDS	Out	LVDS data out negative - Channel 6
C19	doutn4	LVDS	Out	LVDS data out negative - Channel 4
C20	doutp3	LVDS	Out	LVDS data out positive - Channel 3
C21	doutn1	LVDS	Out	LVDS data out negative - Channel 1
C22	gnd_colbias	Ground		Column biasing ground - Connect to ground
C23	gnd_colbias	Ground		Column biasing ground - Connect to ground
C24	gnd_colbias	Ground		Column biasing ground - Connect to ground
C25	vddd_33	Supply		Digital supply - 3.3 V domain
D01	mbs1_out	Analog	Out	For test purposes only. Do not connect
D02	adc_dout5	CMOS	Out	For test purposes only. Do not connect
D03	adc_dout10	CMOS	Out	For test purposes only. Do not connect
D04	gnd_colbias	Ground		Column biasing ground - Connect to ground

## NOIP1SN025KA, NOIP1SN016KA, NOIP1SN012KA

**Table 24. PIN DESCRIPTION**

Pin No.	Name	Type	Direction	Description
D05	clock_outp	LVDS	Out	LVDS clock out positive
D06	doutn31	LVDS	Out	LVDS data out negative - Channel 31
D07	doutn29	LVDS	Out	LVDS data out negative - Channel 29
D08	doutn26	LVDS	Out	LVDS data out negative - Channel 26
D09	doutn24	LVDS	Out	LVDS data out negative - Channel 24
D10	doutn22	LVDS	Out	LVDS data out negative - Channel 22
D11	doutn20	LVDS	Out	LVDS data out negative - Channel 20
D12	doutn18	LVDS	Out	LVDS data out negative - Channel 18
D13	doutp15	LVDS	Out	LVDS data out positive - Channel 15
D14	doutp13	LVDS	Out	LVDS data out positive - Channel 13
D15	doutp11	LVDS	Out	LVDS data out positive - Channel 11
D16	doutp9	LVDS	Out	LVDS data out positive - Channel 9
D17	doutp7	LVDS	Out	LVDS data out positive - Channel 7
D18	doutp5	LVDS	Out	LVDS data out positive - Channel 5
D19	doutp2	LVDS	Out	LVDS data out positive - Channel 2
D20	doutp0	LVDS	Out	LVDS data out positive - Channel 0
D21	syncp	LVDS	Out	LVDS sync positive
D22	gnd_colbias	Ground		Column biasing ground - Connect to ground
D23	miso	CMOS	Out	SPI master in -slave out
D24	mosi	CMOS	In	SPI master out - slave in
D25	ss_n	CMOS	In	SPI slave select (active low)
E01	adc_dout0	CMOS	Out	For test purposes only. Do not connect
E02	adc_dout4	CMOS	Out	For test purposes only. Do not connect
E03	srd2_n	Analog		Not connected
E04	gnd_colbias	Ground		Column biasing ground - Connect to ground
E05	clock_outn	LVDS	Out	LVDS clock out negative
E06	doutp31	LVDS	Out	LVDS data out positive - Channel 31
E07	doutp29	LVDS	Out	LVDS data out positive - Channel 29
E08	doutp26	LVDS	Out	LVDS data out positive - Channel 26
E09	doutp24	LVDS	Out	LVDS data out positive - Channel 24
E10	doutp22	LVDS	Out	LVDS data out positive - Channel 22
E11	doutp20	LVDS	Out	LVDS data out positive - Channel 20
E12	doutp18	LVDS	Out	LVDS data out positive - Channel 18
E13	doutn15	LVDS	Out	LVDS data out negative - Channel 15
E14	doutn13	LVDS	Out	LVDS data out negative - Channel 13
E15	doutn11	LVDS	Out	LVDS data out negative - Channel 11
E16	doutn9	LVDS	Out	LVDS data out negative - Channel 9
E17	doutn7	LVDS	Out	LVDS data out negative - Channel 7
E18	doutn5	LVDS	Out	LVDS data out negative - Channel 5
E19	doutn2	LVDS	Out	LVDS data out negative - Channel 2
E20	doutn0	LVDS	Out	LVDS data out negative - Channel 0
E21	syncn	LVDS	Out	LVDS sync negative



## NOIP1SN025KA, NOIP1SN016KA, NOIP1SN012KA

**Table 24. PIN DESCRIPTION**

Pin No.	Name	Type	Direction	Description
E22	gnd_colbias	Ground		Column biasing ground - Connect to ground
E23	trigger	CMOS	In	Trigger
E24	sck	CMOS	In	SPI clock
E25	reset_n	CMOS	In	Active low system reset
F01	adc_dout3	CMOS	Out	For test purposes only. Do not connect
F02	adc_dout6	CMOS	Out	For test purposes only. Do not connect
F03	srd2_nguard	Analog		Not connected
F04	gnd_colbias	Ground		Column biasing ground - Connect to ground
F05	gnd_colbias	Ground		Column biasing ground - Connect to ground
F06	gnd_colbias	Ground		Column biasing ground - Connect to ground
F07	gnd_colbias	Ground		Column biasing ground - Connect to ground
F08	gnd_colbias	Ground		Column biasing ground - Connect to ground
F09	gnd_colbias	Ground		Column biasing ground - Connect to ground
F10	gnd_colbias	Ground		Column biasing ground - Connect to ground
F11	gnd_colbias	Ground		Column biasing ground - Connect to ground
F12	gnd_colbias	Ground		Column biasing ground - Connect to ground
F13	gnd_colbias	Ground		Column biasing ground - Connect to ground
F14	gnd_colbias	Ground		Column biasing ground - Connect to ground
F15	gnd_colbias	Ground		Column biasing ground - Connect to ground
F16	gnd_colbias	Ground		Column biasing ground - Connect to ground
F17	gnd_colbias	Ground		Column biasing ground - Connect to ground
F18	gnd_colbias	Ground		Column biasing ground - Connect to ground
F19	gnd_colbias	Ground		Column biasing ground - Connect to ground
F20	gnd_colbias	Ground		Column biasing ground - Connect to ground
F21	gnd_colbias	Ground		Column biasing ground - Connect to ground
F22	gnd_colbias	Ground		Column biasing ground - Connect to ground
F23	scan_in2	CMOS	In	Scan chain input #2 - Connect to ground
F24	muxmode1	CMOS	In	Selects number of output channels
F25	muxmode0	CMOS	In	Selects number of output channels
G01	adc_dout8	CMOS	Out	For test purposes only. Do not connect
G02	adc_dout7	CMOS	Out	For test purposes only. Do not connect
G03	afe_clk	CMOS	Out	For test purposes only. Do not connect
G04	srd1_nguard	Analog		Not connected
G05	srd1_n	Analog		Not connected
G06	td_anode	Analog	In/Out	Temperature diode - Anode
G07	td_cathode	Analog	In/Out	Temperature diode - Cathode
G08	mbs3_in	Analog	In	Analog test input - Connect to ground
G09	mbs4_in	Analog	In	Analog test input - Connect to ground
G10	spare_ana	Analog	Out	For test purposes only. Do not connect
G11	spare_ana	Analog	Out	For test purposes only. Do not connect
G12	spare_dig_in	CMOS	In	Digital test input - Connect to ground
G13	spare_dig_in	CMOS	In	Digital test input - Connect to ground

## NOIP1SN025KA, NOIP1SN016KA, NOIP1SN012KA

**Table 24. PIN DESCRIPTION**

Pin No.	Name	Type	Direction	Description
G14	spare_dig_in	CMOS	In	Digital test input - Connect to ground
G15	gnd_colbias	Ground		Column biasing ground - Connect to ground
G16	gnd_colbias	Ground		Column biasing ground - Connect to ground
G17	gnd_colbias	Ground		Column biasing ground - Connect to ground
G18	gnd_colbias	Ground		Column biasing ground - Connect to ground
G19	gnd_colbias	Ground		Column biasing ground - Connect to ground
G20	gnd_colbias	Ground		Column biasing ground - Connect to ground
G21	gnd_colbias	Ground		Column biasing ground - Connect to ground
G22	scan_clk	CMOS	In	Scan chain clock - Connect to ground
G23	monitor2	CMOS	Out	Monitor output #2
G24	monitor1	CMOS	Out	Monitor output #1
G25	monitor0	CMOS	Out	Monitor output #0
H21	test_enable	CMOS	In	Test enable - Connect to ground
H22	adc_mode	CMOS	In	Connect to Gndd_33 ('0')
H23	spare_dig_out	CMOS		Not connected
H24	spare_dig_out	CMOS		Not connected
H25	spare_dig_out	CMOS		Not connected
J01	spare_vref6t_hv	Analog		Not connected
J02	spare_vref6t_hv	Analog		Not connected
J03	spare_vref6t_hv	Analog		Not connected
J04	spare_vref6t_hv	Analog		Not connected
J05	gndd_33	Ground		Digital ground - 3.3 V domain
J06	gndd_33	Ground		Digital ground - 3.3 V domain
J07	gndd_33	Ground		Digital ground - 3.3 V domain
J08	gndd_33	Ground		Digital ground - 3.3 V domain
J09	gndd_33	Ground		Digital ground - 3.3 V domain
J10	gndd_33	Ground		Digital ground - 3.3 V domain
J11	gndd_33	Ground		Digital ground - 3.3 V domain
J12	gndd_33	Ground		Digital ground - 3.3 V domain
J13	gndd_18	Ground		Digital ground - 1.8 V domain
J14	gndd_18	Ground		Digital ground - 1.8 V domain
J15	gndd_18	Ground		Digital ground - 1.8 V domain
J16	gndd_18	Ground		Digital ground - 1.8 V domain
J17	gndd_18	Ground		Digital ground - 1.8 V domain
J18	gndd_18	Ground		Digital ground - 1.8 V domain
J19	gndd_18	Ground		Digital ground - 1.8 V domain
J20	gndd_18	Ground		Digital ground - 1.8 V domain
J21	gndd_18	Ground		Digital ground - 1.8 V domain
J22	gnd_calib	Ground		Pixel calibration ground - Connect to ground
J23	gnd_trans	Supply		Pixel transfer ground - sinking supply
J24	gnd_resfd	Ground		Floating diffusion reset ground - Connect to ground
J25	gnd_resfd	Ground		Floating diffusion reset ground - Connect to ground

## NOIP1SN025KA, NOIP1SN016KA, NOIP1SN012KA

**Table 24. PIN DESCRIPTION**

Pin No.	Name	Type	Direction	Description
K01	spare_vref6t	Analog		Not connected
K02	spare_vref6t	Analog		Not connected
K03	spare_vref6t	Analog		Not connected
K04	spare_vref6t	Analog		Not connected
K05	spare_vref6t	Analog		Not connected
K06	spare_vref6t	Analog		Not connected
K07	spare_vref6t	Analog		Not connected
K08	spare_vref6t	Analog		Not connected
K9	vdd_pix	Supply		Pixel array supply
K10	vdd_pix	Supply		Pixel array supply
K11	vdd_pix	Supply		Pixel array supply
K12	vdd_pix	Supply		Pixel array supply
K13	vdd_pix	Supply		Pixel array supply
K14	vdd_pix	Supply		Pixel array supply
K15	vdd_pix	Supply		Pixel array supply
K16	vdd_pix	Supply		Pixel array supply
K17	gnd_sel	Ground		Pixel select ground - Connect to ground
K18	gnd_sel	Ground		Pixel select ground - Connect to ground
K19	gnd_sel	Ground		Pixel select ground - Connect to ground
K20	gnd_sel	Ground		Pixel select ground - Connect to ground
K21	vdd_calib	Supply		Pixel calibration supply
K22	gnd_calib	Ground		Pixel calibration ground - Connect to ground
K23	gnd_trans	Supply		Pixel transfer ground - sinking supply
K24	gnd_resfd	Ground		Floating diffusion reset ground - Connect to ground
K25	gnd_resfd	Ground		Floating diffusion reset ground - Connect to ground
L01	vref_colmux	Supply		Column multiplexer reference supply
L02	vdd_pix	Supply		Pixel array supply
L03	vdd_pix	Supply		Pixel array supply
L04	vdd_pix	Supply		Pixel array supply
L05	vdd_pix	Supply		Pixel array supply
L06	vdd_pix	Supply		Pixel array supply
L07	vdd_pix	Supply		Pixel array supply
L08	vdd_pix	Supply		Pixel array supply
L09	vdd_pix	Supply		Pixel array supply
L10	vdd_pix	Supply		Pixel array supply
L11	vdd_pix	Supply		Pixel array supply
L12	vdd_pix	Supply		Pixel array supply
L13	vdd_pix	Supply		Pixel array supply
L14	vdd_pix	Supply		Pixel array supply
L15	vdd_pix	Supply		Pixel array supply
L16	vdd_pix	Supply		Pixel array supply
L17	vdd_casc	Supply		Cascode supply

## NOIP1SN025KA, NOIP1SN016KA, NOIP1SN012KA

**Table 24. PIN DESCRIPTION**

Pin No.	Name	Type	Direction	Description
L18	vdd_casc	Supply		Cascode supply
L19	vdd_sel	Supply		Pixel select supply
L20	vdd_sel	Supply		Pixel select supply
L21	vdd_calib	Supply		Pixel calibration supply
L22	gnd_calib	Ground		Pixel calibration ground - Connect to ground
L23	gnd_trans	Supply		Pixel transfer ground - sinking supply
L24	vdd_resfd	Supply		Floating diffusion reset supply
L25	vref_colmux	Supply		Column multiplexer reference supply
M01	vref_colmux	Supply		Column multiplexer reference supply
M02	vdd_pix	Supply		Pixel array supply
M03	vdd_pix	Supply		Pixel array supply
M04	vdd_pix	Supply		Pixel array supply
M05	vdd_pix	Supply		Pixel array supply
M06	vdd_pix	Supply		Pixel array supply
M07	vdd_pix	Supply		Pixel array supply
M08	vdd_pix	Supply		Pixel array supply
M09	vdd_pix	Supply		Pixel array supply
M10	vdd_pix	Supply		Pixel array supply
M11	vdd_pix	Supply		Pixel array supply
M12	vdd_pix	Supply		Pixel array supply
M13	vdd_pix	Supply		Pixel array supply
M14	vdd_pix	Supply		Pixel array supply
M15	vdd_pix	Supply		Pixel array supply
M16	vdd_pix	Supply		Pixel array supply
M17	vdd_casc	Supply		Cascode supply
M18	vdd_casc	Supply		Cascode supply
M19	vdd_sel	Supply		Pixel select supply
M20	vdd_sel	Supply		Pixel select supply
M21	vdd_calib	Supply		Pixel calibration supply
M22	gnd_calib	Ground		Pixel calibration ground - Connect to ground
M23	gnd_trans	Supply		Pixel transfer ground - sinking supply
M24	vdd_resfd	Supply		Floating diffusion reset supply
M25	vref_colmux	Supply		Column multiplexer reference supply
N01	vddd_33	Supply		Digital supply - 3.3-V domain
N02	vdd_pix	Supply		Pixel array supply
N03	gnd_colpc	Ground		Column precharge ground - Connect to ground
N04	gnd_colpc	Ground		Column precharge ground - Connect to ground
N05	gnd_colpc	Ground		Column precharge ground - Connect to ground
N06	gnd_colpc	Ground		Column precharge ground - Connect to ground
N07	gnd_colpc	Ground		Column precharge ground - Connect to ground
N08	gnd_colpc	Ground		Column precharge ground - Connect to ground
N09	gnd_colpc	Ground		Column precharge ground - Connect to ground

## NOIP1SN025KA, NOIP1SN016KA, NOIP1SN012KA

**Table 24. PIN DESCRIPTION**

Pin No.	Name	Type	Direction	Description
N10	gnd_colpc	Ground		Column precharge ground - Connect to ground
N11	gnd_colpc	Ground		Column precharge ground - Connect to ground
N12	gnd_colpc	Ground		Column precharge ground - Connect to ground
N13	gnd_colpc	Ground		Column precharge ground - Connect to ground
N14	gnd_colpc	Ground		Column precharge ground - Connect to ground
N15	gnd_colpc	Ground		Column precharge ground - Connect to ground
N16	gnd_colpc	Ground		Column precharge ground - Connect to ground
N17	gnd_colpc	Ground		Column precharge ground - Connect to ground
N18	gnd_colpc	Ground		Column precharge ground - Connect to ground
N19	gnd_colpc	Ground		Column precharge ground - Connect to ground
N20	gnd_colpc	Ground		Column precharge ground - Connect to ground
N21	vdd_calib	Supply		Pixel calibration supply
N22	vdd_trans	Supply		Pixel transfer supply
N23	vdd_trans	Supply		Pixel transfer supply
N24	vdd_resfd	Supply		Floating diffusion reset supply
N25	vddd_33	Supply		Digital supply - 3.3 V domain
P01	vddd_33	Supply		Digital supply - 3.3 V domain
P02	vdd_pix	Supply		Pixel array supply
P03	gnd_colpc	Ground		Column precharge ground - Connect to ground
P04	gnd_colpc	Ground		Column precharge ground - Connect to ground
P05	gnd_colpc	Ground		Column precharge ground - Connect to ground
P06	gnd_colpc	Ground		Column precharge ground - Connect to ground
P07	gnd_colpc	Ground		Column precharge ground - Connect to ground
P08	gnd_colpc	Ground		Column precharge ground - Connect to ground
P09	gnd_colpc	Ground		Column precharge ground - Connect to ground
P10	gnd_colpc	Ground		Column precharge ground - Connect to ground
P11	gnd_colpc	Ground		Column precharge ground - Connect to ground
P12	gnd_colpc	Ground		Column precharge ground - Connect to ground
P13	gnd_colpc	Ground		Column precharge ground - Connect to ground
P14	gnd_colpc	Ground		Column precharge ground - Connect to ground
P15	gnd_colpc	Ground		Column precharge ground - Connect to ground
P16	gnd_colpc	Ground		Column precharge ground - Connect to ground
P17	gnd_colpc	Ground		Column precharge ground - Connect to ground
P18	gnd_colpc	Ground		Column precharge ground - Connect to ground
P19	gnd_colpc	Ground		Column precharge ground - Connect to ground
P20	gnd_colpc	Ground		Column precharge ground - Connect to ground
P21	gnd_colpc	Ground		Column precharge ground - Connect to ground
P22	vdd_trans	Supply		Pixel transfer supply
P23	vdd_trans	Supply		Pixel transfer supply
P24	vdd_resfd	Supply		Floating diffusion reset supply
P25	vddd_33	Supply		Digital supply - 3.3 V domain
R01	vddd_18	Supply		Digital supply - 1.8 V domain

**NOIP1SN025KA, NOIP1SN016KA, NOIP1SN012KA**

**Table 24. PIN DESCRIPTION**

Pin No.	Name	Type	Direction	Description
R02	vddd_18	Supply		Digital supply - 1.8 V domain
R03	vddd_18	Supply		Digital supply - 1.8 V domain
R04	gnd_colpc	Ground		Column precharge ground - Connect to ground
R05	gnda_33	Ground		Analog ground - 3.3 V domain
R06	gnda_33	Ground		Analog ground - 3.3 V domain
R07	gnda_33	Ground		Analog ground - 3.3 V domain
R08	gnda_33	Ground		Analog ground - 3.3 V domain
R09	gnda_33	Ground		Analog ground - 3.3 V domain
R10	gnda_33	Ground		Analog ground - 3.3 V domain
R11	gnda_33	Ground		Analog ground - 3.3 V domain
R12	gnda_33	Ground		Analog ground - 3.3 V domain
R13	gnda_33	Ground		Analog ground - 3.3 V domain
R14	gnda_33	Ground		Analog ground - 3.3 V domain
R15	gnda_33	Ground		Analog ground - 3.3 V domain
R16	gnda_33	Ground		Analog ground - 3.3 V domain
R17	gnda_33	Ground		Analog ground - 3.3 V domain
R18	gnda_33	Ground		Analog ground - 3.3 V domain
R19	gnda_33	Ground		Analog ground - 3.3 V domain
R20	gnda_33	Ground		Analog ground - 3.3 V domain
R21	gnda_33	Ground		Analog ground - 3.3 V domain
R22	gnda_33	Ground		Analog ground - 3.3 V domain
R23	vddd_18	Supply		Digital supply - 1.8 V domain
R24	vddd_18	Supply		Digital supply - 1.8 V domain
R25	vddd_18	Supply		Digital supply - 1.8 V domain

# NOIP1SN025KA, NOIP1SN016KA, NOIP1SN012KA

## Mechanical Specifications

**Table 25. MECHANICAL SPECIFICATIONS**

Parameter	Description	Min	Typ	Max	Units
Die	Die thickness		725		μm
	Die size		25.5 x 32.5		mm <sup>2</sup>
	Die center, X offset to the center of package	-50	0	50	μm
	Die center, Y offset to the center of the package	-50	0	50	μm
	Die position, tilt to the Die Attach Plane	-1	0	1	deg
	Die rotation accuracy (referenced to die scribe and lead fingers on package on all four sides)	-1	0	1	deg
	Optical center referenced from the die/package center (X-dir)		0		μm
	Optical center referenced from the die/package center (Y-dir)		3602		μm
	Distance from bottom of the package to top of the die surface	1.605	1.80	1.995	mm
	Distance from top of the die surface to top of the glass lid	1.075	1.45	1.855	mm
Glass Lid Specification	XY size		32.47 x 39.4		mm <sup>2</sup>
	Thickness		0.7		mm
	Spectral response range	400		1000	nm
	Transmission of glass lid (refer to Figure 44)		92		%
Glass Lid Material	D263 Teco (no coatings on glass)				
Mechanical Shock	JESD22-B104C; Condition G			2000	g
Vibration	JESD22-B103B; Condition 1			2000	Hz
Mounting Profile	Pb-free wave soldering profile for pin grid array package				
Recommended Socket	Andon Electronics Corporation ( <a href="http://www.andonelectronics.com">www.andonelectronics.com</a> )	10-31-13A-355-400T4-R27-L14			

NOTE: Optical center min/max tolerance is calculated on X/Y package tolerances with package center as a reference.

# NOIP1SN025KA, NOIP1SN016KA, NOIP1SN012KA

## Package Drawing



All dimensions are in mm, unless specified otherwise.

Figure 49. PYTHON XK Package Diagram



# NOIP1SN025KA, NOIP1SN016KA, NOIP1SN012KA

**Table 26. OPTICAL CENTER INFORMATION FOR THE PYTHON 25K/16K/12K IN 355-PIN  $\mu$ PGA PACKAGE**

	References*	PYTHON 25K		PYTHON 16K		PYTHON 12K	
		X(um)	Y(um)	X(um)	Y(um)	X(um)	Y(um)
Die Outer Coordinates	D1	0	32500	0	32500	0	32500
	D2	25500	32500	25500	32500	25500	32500
	D3	25500	0	25500	0	25500	0
	D4	0	0	0	0	0	0
Die Center	CD	12750	16250	12750	16250	12750	16250
Active Area Co-ordinates	A1	1211.785	31389.11	1211.785	31389.11	1211.785	31389.11
	A2	24287.79	31389.11	24287.79	31389.11	24287.79	31389.11
	A3	24287.79	8313.11	24287.79	8313.11	24287.79	8313.11
	A4	1211.785	8313.11	1211.785	8313.11	1211.785	8313.11
Active Area Center	AA	12749.79	19851.11	12461.79	19851.11	12461.79	19851.11
	Pitch	4.5	4.5	4.5	4.5	4.5	4.5
	# Pixels	5128	5128	5128	5128	5128	5128
	# Dummy	8	8	904	1016	904	2040
	# Active Pixels	5120	5120	4224	4112	4224	3088
	Act_A1	1229.785	31371.11	2957.785	29103.11	2957.785	26799.11
	Act_A2	24269.79	31371.11	21965.79	29103.11	21965.79	26799.11
	Act_A3	24269.79	8331.11	21965.79	10599.11	21965.79	12903.11
	Act_A4	1229.785	8331.11	2957.785	10599.11	2957.785	12903.11

\*Refer to Figure 50 below.

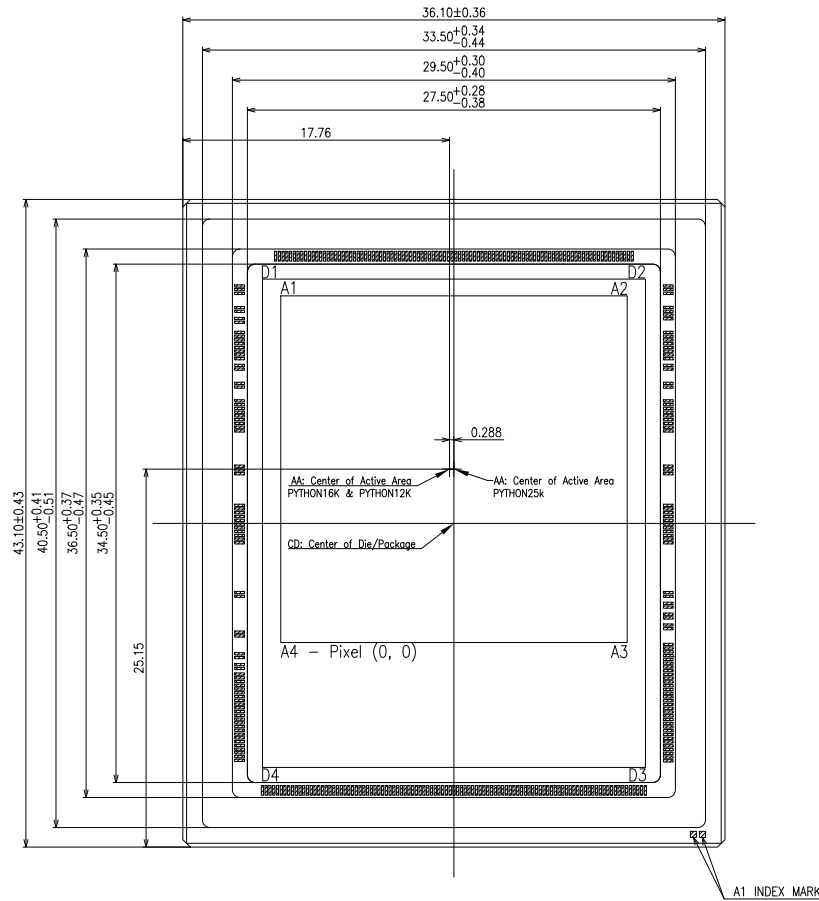

**Figure 50. Graphical Representation of the Optical Center**

## NOIP1SN025KA, NOIP1SN016KA, NOIP1SN012KA

### Glass Lid

The PYTHON XK image sensor uses a glass lid without any coatings. Figure 51 shows the transmission characteristics of the glass lid.

As seen in Figure 51, the sensor does not have an infrared attenuating filter glass. A filter must be provided in the optical path when color devices are used (source: <http://www.pgo-online.com>).



Figure 51. Transmission Characteristics of Glass Lid

### SPECIFICATIONS AND USEFUL REFERENCES

Specifications, Application Notes and useful resources can be accessible via customer login account at MyOn - ISG Extranet.

<https://www.onsemi.com/PowerSolutions/myon/erCispFol der.do>

#### Useful References

For information on ESD and cover glass care and cleanliness, please download the *Image Sensor Handling and Best Practices* Application Note ([AN52561/D](#)) from [www.onsemi.com](http://www.onsemi.com).

For quality and reliability information, please download the *Quality & Reliability Handbook* ([HBD851/D](#)) from [www.onsemi.com](http://www.onsemi.com).

For information on Standard terms and Conditions of Sale, please download [Terms and Conditions](#) from [www.onsemi.com](http://www.onsemi.com).

#### Application Note and References

- PYTHON XK Layout DSN drawing
- PYTHON XK 3D package STP file for CAD

#### Acceptance Criteria Specification

The Product Acceptance Criteria is available on request. This document contains the criteria to which the PYTHON XK is tested prior to being shipped.

#### Return Material Authorization (RMA)

Refer to the ON Semiconductor RMA policy procedure at [http://www.onsemi.com/site/pdf/CAT>Returns\\_FailureAnalysis.pdf](http://www.onsemi.com/site/pdf/CAT>Returns_FailureAnalysis.pdf)

ACRONYMS

Acronym	Description
ADC	Analog-to-Digital Converter
AFE	Analog Front End
BL	Black pixel data
CDM	Charged Device Model
CDS	Correlated Double Sampling
CMOS	Complementary Metal Oxide Semiconductor
CRC	Cyclic Redundancy Check
DAC	Digital-to-Analog Converter
DDR	Double Data Rate
DNL	Differential Non-Linearity
DS	Double Sampling
EIA	Electronic Industries Alliance
ESD	Electrostatic Discharge
FE	Frame End
FOT	Frame Overhead Time
FPGA	Field Programmable Gate Array
FPN	Fixed Pattern Noise
FPS	Frame per Second
FS	Frame Start
HBM	Human Body Model
IMG	Image data (regular pixel data)
INL	Integral Non-Linearity
IP	Intellectual Property

Acronym	Description
LE	Line End
LS	Line Start
LSB	least significant bit
LVDS	Low-Voltage Differential Signaling
MSB	most significant bit
PGA	Programmable Gain Amplifier
PLS	Parasitic Light Sensitivity
PRBS	Pseudo-Random Binary Sequence
PRNU	Photo Response Non-Uniformity
QE	Quantum Efficiency
RGB	Red-Green-Blue
RMA	Return Material Authorization
RMS	Root Mean Square
ROI	Region of Interest
ROT	Row Overhead Time
S/H	Sample and Hold
SNR	Signal-to-Noise Ratio
SPI	Serial Peripheral Interface
TIA	Telecommunications Industry Association
T <sub>J</sub>	Junction temperature
TR	Training pattern
% RH	Percent Relative Humidity

GLOSSARY

conversion gain	A constant that converts the number of electrons collected by a pixel into the voltage swing of the pixel. Conversion gain = $q/C$ where $q$ is the charge of an electron ( $1.602E-19$ Coulomb) and $C$ is the capacitance of the photodiode or sense node.
CDS	Correlated double sampling. This is a method for sampling a pixel where the pixel voltage after reset is sampled and subtracted from the voltage after exposure to light.
CFA	Color filter array. The materials deposited on top of pixels that selectively transmit color.
DNL	Differential non-linearity (for ADCs)
DSNU	Dark signal non-uniformity. This parameter characterizes the degree of non-uniformity in dark leakage currents, which can be a major source of fixed pattern noise.
fill-factor	A parameter that characterizes the optically active percentage of a pixel. In theory, it is the ratio of the actual QE of a pixel divided by the QE of a photodiode of equal area. In practice, it is never measured.
INL	Integral nonlinearity (for ADCs)
IR	Infrared. IR light has wavelengths in the approximate range 750 nm to 1 mm.
Lux	Photometric unit of luminance (at 550 nm, $1\text{lux} = 1 \text{ lumen/m}^2 = 1/683 \text{ W/m}^2$ )
pixel noise	Variation of pixel signals within a region of interest (ROI). The ROI typically is a rectangular portion of the pixel array and may be limited to a single color plane.
photometric units	Units for light measurement that take into account human physiology.
PLS	Parasitic light sensitivity. Parasitic discharge of sampled information in pixels that have storage nodes.
PRNU	Photo-response non-uniformity. This parameter characterizes the spread in response of pixels, which is a source of FPN under illumination.
QE	Quantum efficiency. This parameter characterizes the effectiveness of a pixel in capturing photons and converting them into electrons. It is photon wavelength and pixel color dependent.
read noise	Noise associated with all circuitry that measures and converts the voltage on a sense node or photodiode into an output signal.
reset	The process by which a pixel photodiode or sense node is cleared of electrons. "Soft" reset occurs when the reset transistor is operated below the threshold. "Hard" reset occurs when the reset transistor is operated above threshold.
reset noise	Noise due to variation in the reset level of a pixel. In 3T pixel designs, this noise has a component (in units of volts) proportionality constant depending on how the pixel is reset (such as hard and soft). In 4T pixel designs, reset noise can be removed with CDS.
responsivity	The standard measure of photodiode performance (regardless of whether it is in an imager or not). Units are typically $A/W$ and are dependent on the incident light wavelength. Note that responsivity and sensitivity are used interchangeably in image sensor characterization literature so it is best to check the units.
ROI	Region of interest. The area within a pixel array chosen to characterize noise, signal, crosstalk, and so on. The ROI can be the entire array or a small subsection; it can be confined to a single color plane.
sense node	In 4T pixel designs, a capacitor used to convert charge into voltage. In 3T pixel designs it is the photodiode itself.
sensitivity	A measure of pixel performance that characterizes the rise of the photodiode or sense node signal in Volts upon illumination with light. Units are typically $V/(W/m^2)/\text{sec}$ and are dependent on the incident light wavelength. Sensitivity measurements are often taken with 550 nm incident light. At this wavelength, 1 683 lux is equal to $1 \text{ W/m}^2$ ; the units of sensitivity are quoted in $V/\text{lux}/\text{sec}$ . Note that responsivity and sensitivity are used interchangeably in image sensor characterization literature so it is best to check the units.
spectral response	The photon wavelength dependence of sensitivity or responsivity.
SNR	Signal-to-noise ratio. This number characterizes the ratio of the fundamental signal to the noise spectrum up to half the Nyquist frequency.
temporal noise	Noise that varies from frame to frame. In a video stream, temporal noise is visible as twinkling pixels.

ON Semiconductor and  are trademarks of Semiconductor Components Industries, LLC dba ON Semiconductor or its subsidiaries in the United States and/or other countries. ON Semiconductor owns the rights to a number of patents, trademarks, copyrights, trade secrets, and other intellectual property. A listing of ON Semiconductor's product/patent coverage may be accessed at [www.onsemi.com/site/pdf/Patent-Marking.pdf](http://www.onsemi.com/site/pdf/Patent-Marking.pdf). ON Semiconductor reserves the right to make changes without further notice to any products herein. ON Semiconductor makes no warranty, representation or guarantee regarding the suitability of its products for any particular purpose, nor does ON Semiconductor assume any liability arising out of the application or use of any product or circuit, and specifically disclaims any and all liability, including without limitation special, consequential or incidental damages. Buyer is responsible for its products and applications using ON Semiconductor products, including compliance with all laws, regulations and safety requirements or standards, regardless of any support or applications information provided by ON Semiconductor. "Typical" parameters which may be provided in ON Semiconductor data sheets and/or specifications can and do vary in different applications and actual performance may vary over time. All operating parameters, including "Typicals" must be validated for each customer application by customer's technical experts. ON Semiconductor does not convey any license under its patent rights nor the rights of others. ON Semiconductor products are not designed, intended, or authorized for use as a critical component in life support systems or any FDA Class 3 medical devices or medical devices with a same or similar classification in a foreign jurisdiction or any devices intended for implantation in the human body. Should Buyer purchase or use ON Semiconductor products for any such unintended or unauthorized application, Buyer shall indemnify and hold ON Semiconductor and its officers, employees, subsidiaries, affiliates, and distributors harmless against all claims, costs, damages, and expenses, and reasonable attorney fees arising out of, directly or indirectly, any claim of personal injury or death associated with such unintended or unauthorized use, even if such claim alleges that ON Semiconductor was negligent regarding the design or manufacture of the part. ON Semiconductor is an Equal Opportunity/Affirmative Action Employer. This literature is subject to all applicable copyright laws and is not for resale in any manner.

## PUBLICATION ORDERING INFORMATION

### LITERATURE FULFILLMENT:

Literature Distribution Center for ON Semiconductor  
19521 E. 32nd Pkwy, Aurora, Colorado 80011 USA  
**Phone:** 303-675-2175 or 800-344-3860 Toll Free USA/Canada  
**Fax:** 303-675-2176 or 800-344-3867 Toll Free USA/Canada  
**Email:** [orderlit@onsemi.com](mailto:orderlit@onsemi.com)

**N. American Technical Support:** 800-282-9855 Toll Free  
USA/Canada  
**Europe, Middle East and Africa Technical Support:**  
Phone: 421 33 790 2910

**ON Semiconductor Website:** [www.onsemi.com](http://www.onsemi.com)

**Order Literature:** <http://www.onsemi.com/orderlit>

For additional information, please contact your local  
Sales Representative