

C4180

CMOS 12 MP

10G GigE Vision®



Imperx: C4180

The 10G GigE C4180 camera features the ON Semiconductor Python NOIP1xx012KA CMOS image sensor with a native resolution of 4096 x 3072 in a 4/3" optical format. The GenICam™ compliant camera delivers up to 80.4 frames per second in global shutter mode using the GigE Vision standard interface. CMOS technology eliminates smear columns from areas of ultra-bright intensity and specular reflections in uncontrolled lighting applications. The Imperx Cheetah line provides excellent image quality with Imperx proprietary processing. In addition, Imperx puts you in control and gives you full access to raw data without corrections. Using the simple, intuitive graphical user interface, you can quickly apply or remove image corrections. Flexibility and image quality make the C4180 suitable for a broad range of diverse and demanding applications. Imperx can help optimize the camera to your exacting requirements.

Specifications

Feature	Description	Feature	Description
Output Interface	10G GigE Vision	Strobe Output	2 strobes, programmable position and duration
Resolution	4096 (H) x 3072 (V)	Pulse Generator	Yes, programmable
Sensor	Python NOIP1xx012KA, CMOS Color/Mono/ENIR	Data Corrections	2 LUTs pre-programmed with Gamma 0.45 Defective/hot pixel correction (static, dynamic), Flat field correction, Fixed pattern noise correction
Sensor Format	18.4 mm (H) 13.8 mm (V), 4/3" optical format	Lens Mount	F-Mount (Default), M42, EF Canon (passive or active)
Pixel Size	4.5 microns square	Supply Voltage Range	12 V DC (5V - 33V) 1.5 A inrush without enabled Canon controller 12 V DC (6.5V - 33V) 1.5 A inrush with enabled Canon controller
NIR Sensitivity	Mono: 850 nm: 18%, 950 nm: 6% ENIR: 850 nm: 30%, 950 nm: 11%	Camera Current	Typical: 1.1 A, Maximum: 1.2 A
Shutter	Global shutter (GS)	Size - Width/Height/Length	72.0 mm (W) x 72.0 mm (H) x 72.3 mm (L)
Fixed Pattern Noise	<0.9 LSB	Weight	579.5 g
Sensor Digitization	10-bit	Vibration, Shock	Complies with IEC60068-2-64 and IEC60068-2-27
Frame Rate	80.4 fps (8-bit), 48 fps (10-bit packed), 44.8 fps (10-bit unpacked)	Environmental	-40°C to +75°C Operating -50°C to +90°C Storage
Dynamic Range	59 dB	Humidity	10% to 90% non-condensing
Output Bit Depth	8, 10-bit	MTBF	>323,000 hours @ 40 °C (Telcordia SR-332)
Analog Gain Control	1x, 1.26x, 1.87x, 3.17x	Military Standard	MIL-STD-810G
Digital Gain	1x (0 dB) to 15.9 (24 dB) with a precision of 0.001x, Auto	Regulatory	FCC Part 15 Class A, CE, RoHS
AEC/AGC	Yes		
Black Level Offset	Manual (-511...+511), Auto		
White Balance	Manual, Auto, Off		
Shutter Speed	1 µs/step, 40 µs to 1.0 s		
Exposure Control	Off, Internal, External, Auto		
Regions of Interest (ROI)	1 ROI		
Averaging Decimation	1 x 2, 2 x 1, 2 x 2		
Sub-sampling Decimation	1 x 2, 2 x 1, 2 x 2		
Trigger Inputs	External, Pulse generator, Software		
Trigger Options	Edge, Debounce		
Trigger Modes	Internal, External, Software		
External Inputs/Outputs	2 IN (OPTO, LVTTTL) / 2 OUT (OPTO, TTL)		

Imperx: C4180 Applications

The C4180 incorporates a number of unique features tailored to reduce system complexity, maximize interface bandwidth, and expand the usable operational range.

Aerospace • Satellites • Surveillance • Military and Non-Military Ground Vehicles • Ball Grid Array • Printed Circuit Board Inspection • Motion Analysis • Broadcast Television • Telepresence • Unmanned Aerial Vehicles • Machine Vision • Reconnaissance • Intelligent Traffic Systems • Aerial Imaging • Open Road Tolling Systems • Situational Awareness

Absolute Quantum Efficiency

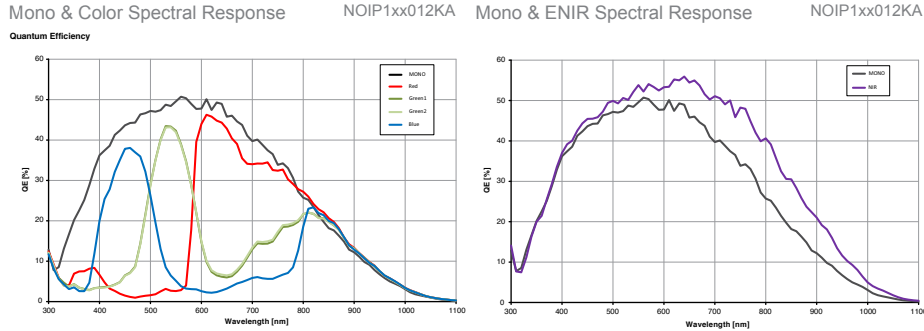

Dimensions

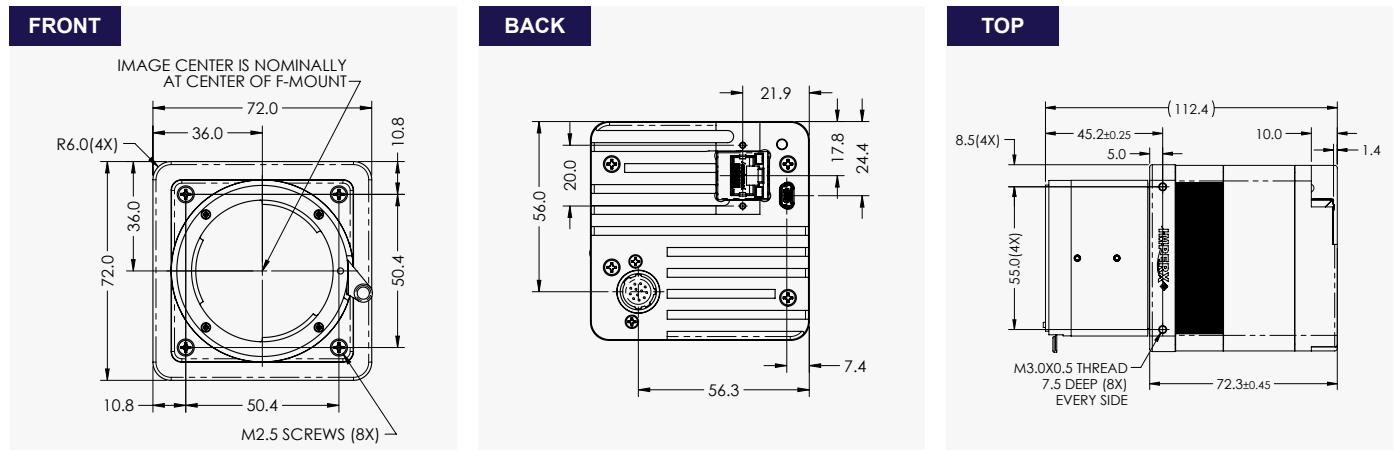

Ordering Information

Output Interface 10G GigE Vision (10G)	Lens Mounts F Mount (Default) M42 EF Canon
Sensor Types available Monochrome Bayer Color NIR	Accessories (Sold separately) PS12V04A-Power Supply w/ 1 input and 1 output

Gen<I>Cam Compliant Camera Configurator

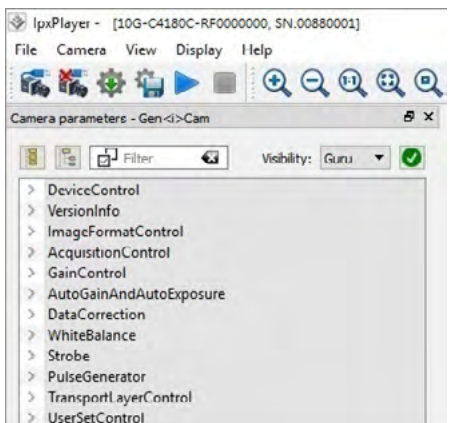

Hirose Connectors

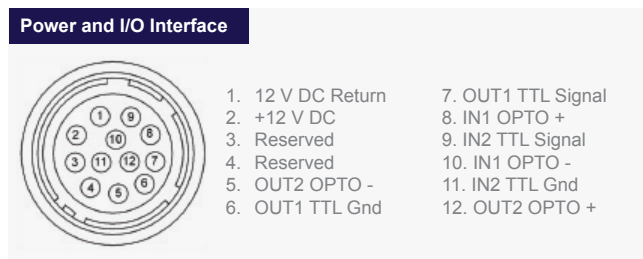

Connector: Hirose HR 10A-10R-12PB(71)

Rev: 10g_c4180_r4_2019

Quality Management System ISO 9001:2015 Registered
 Environmental Management System ISO 14001:2015 Registered
 DDTC Registered (Directorate of Defense Trade Controls, US Department of State)

SAIS Espace Boat 2 route de Gasville 28630
 NOGENT LE PHAYE
 Tel : 09 54 16 23 53 - Fax : 09 59 16 23 53
 contact@sacasa.info - www.sacasa.info

Technical data has been fully checked, but accuracy of printed matter is not guaranteed. Subject to change without notice. Copyright 2019.